



STARPOWER

POWER MODULE PRODUCT CATALOG

- IGBT MODULES
- SiC MODULES
- IGBT DISCRETES
- SiC DISCRETES
- IPM MODULES

CONTENTS

About StarPower 01

Module Nomenclature 02

Solar Power 07

Automotive SiC 09

Automotive IGBT 12

PIM 17

6-Pack 21

All In One 23

2-Pack 24

1-Pack 27

3-Level 28

Discrete Device 29

IPM 31

Package Outlines 34

About StarPower

StarPower Semiconductor Ltd. is a leading power module company located in Jiaxing China about 59 miles southeast of Shanghai. Founded in 2005, StarPower designs and manufactures IGBT/SiC/MOSFET/IPM/FRD modules and customized modules for applications in the area of EV/HEV, solar/wind power, inverters, welding machines, UPS, home appliances and etc. in the power range of 0.5kW up to more than 1MW.

Through heavy investment in R&Ds, we offer a broad range of quality and eco-friendly products and services to our customers. We are committed to excellence in all things we do. The company has one of the best production lines and well-trained workforce in the industry. Our mission is to create the most value for the success of our customers around the globe.

For more information, please go to our website at **www.powersemi.com** or call our sales hotline at: **+86 573 82585700**(China); or go to our StarPower Europe website at **www.starpowereurope.com**, or call **+41 91 8504141**(Europe).

IGBT Module Nomenclature

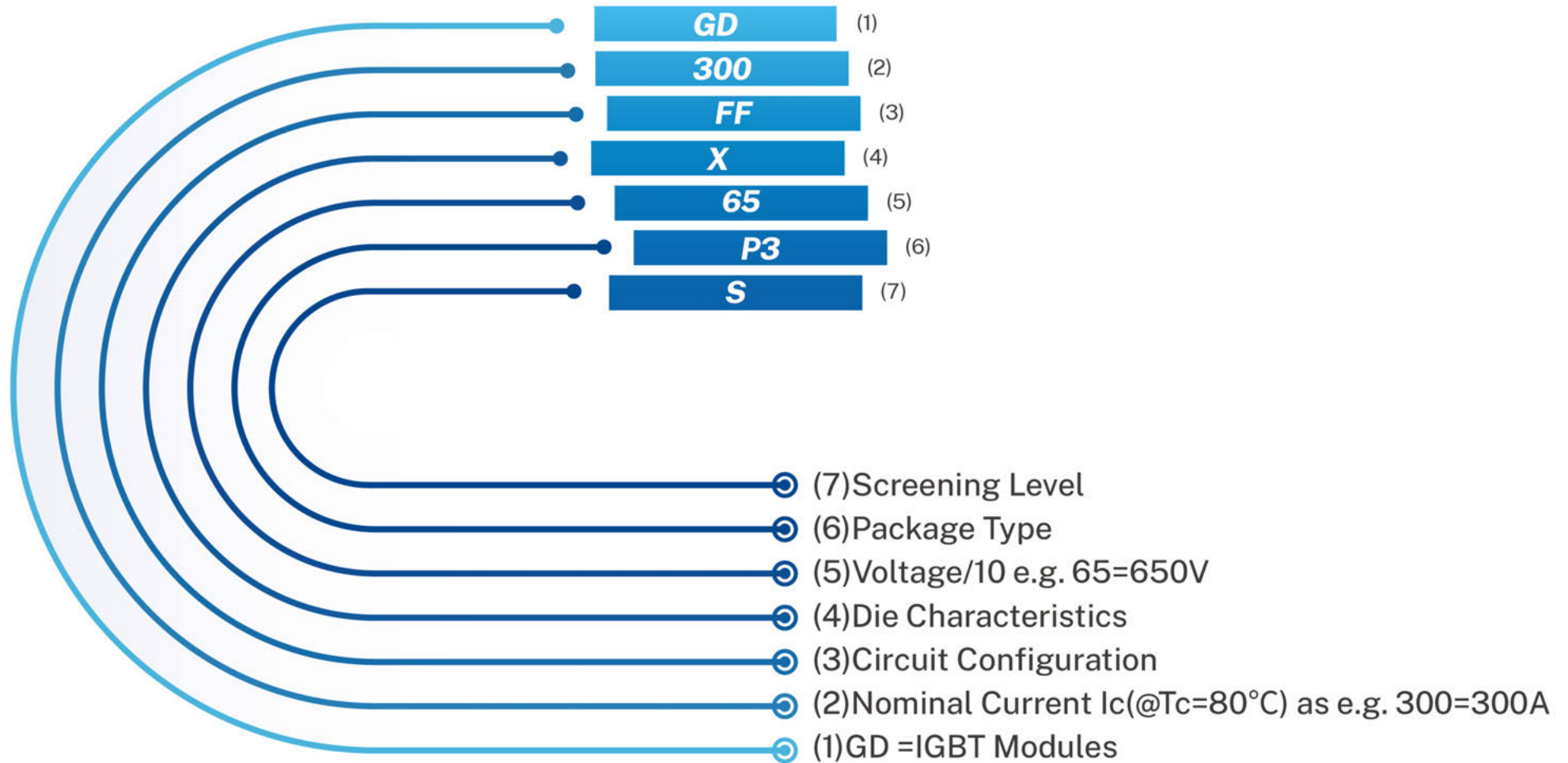

SiC Module Nomenclature

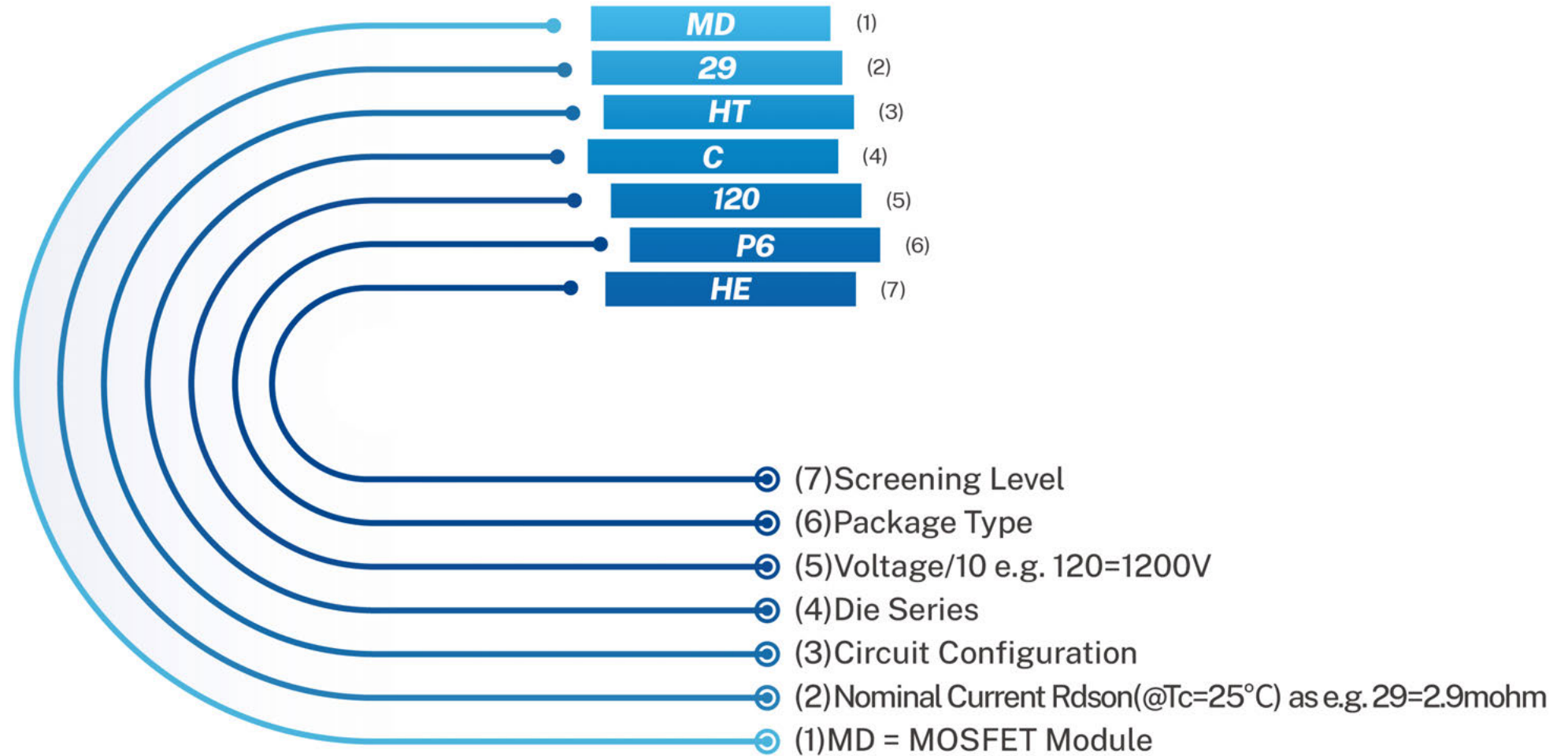

IGBT Discretes Nomenclature

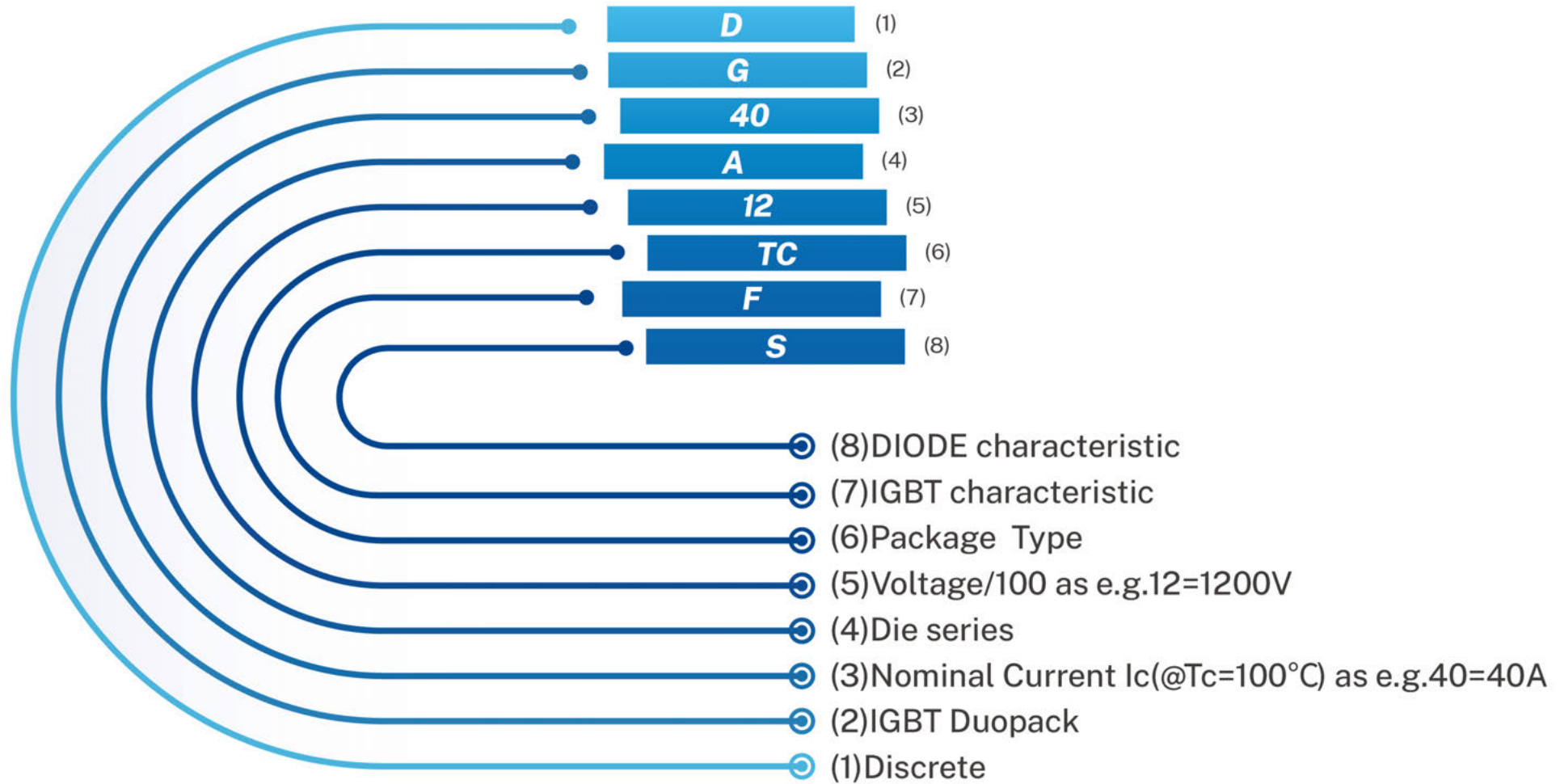

SiC Discrettes Nomenclature

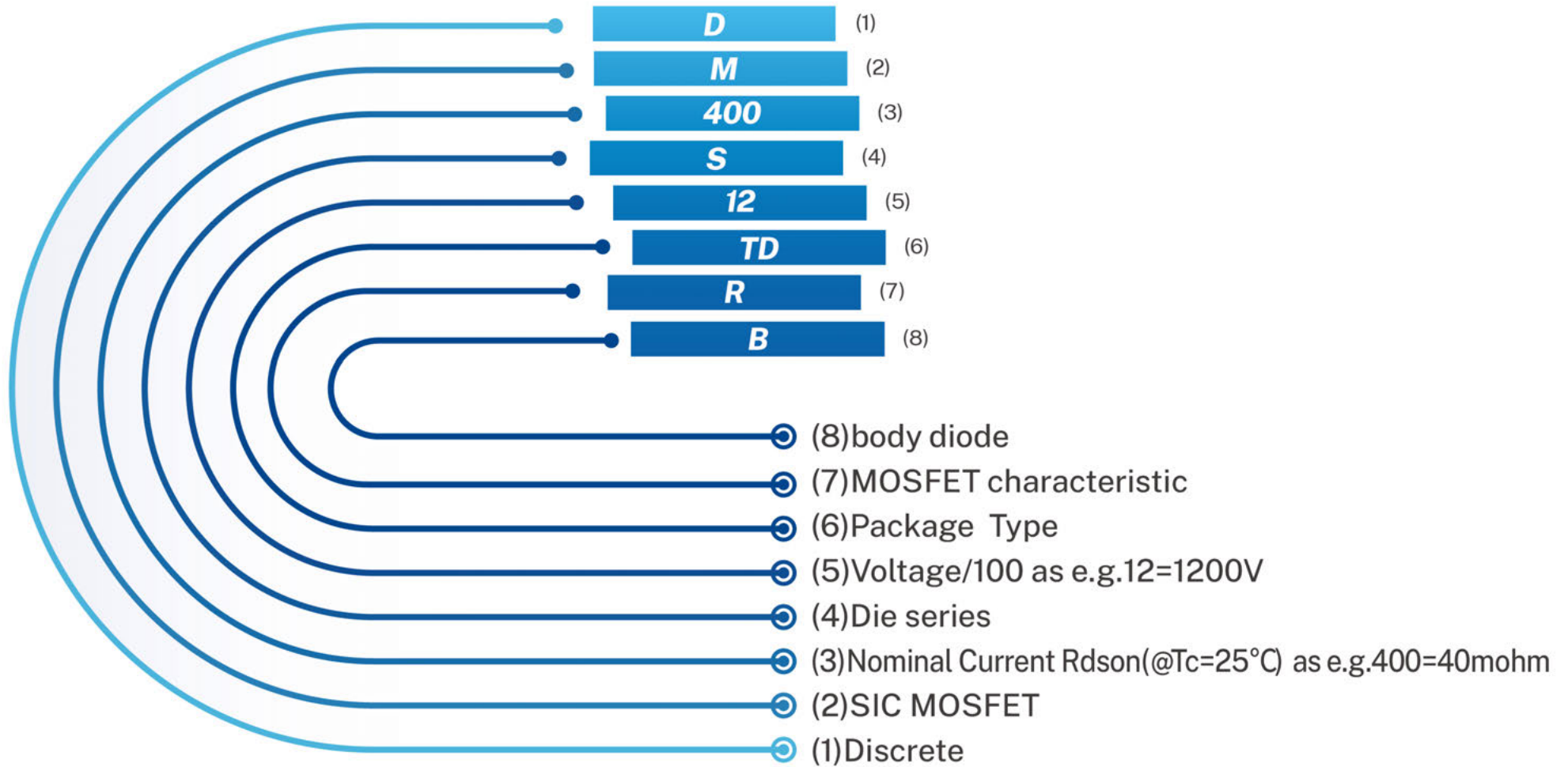

IPM Module Nomenclature

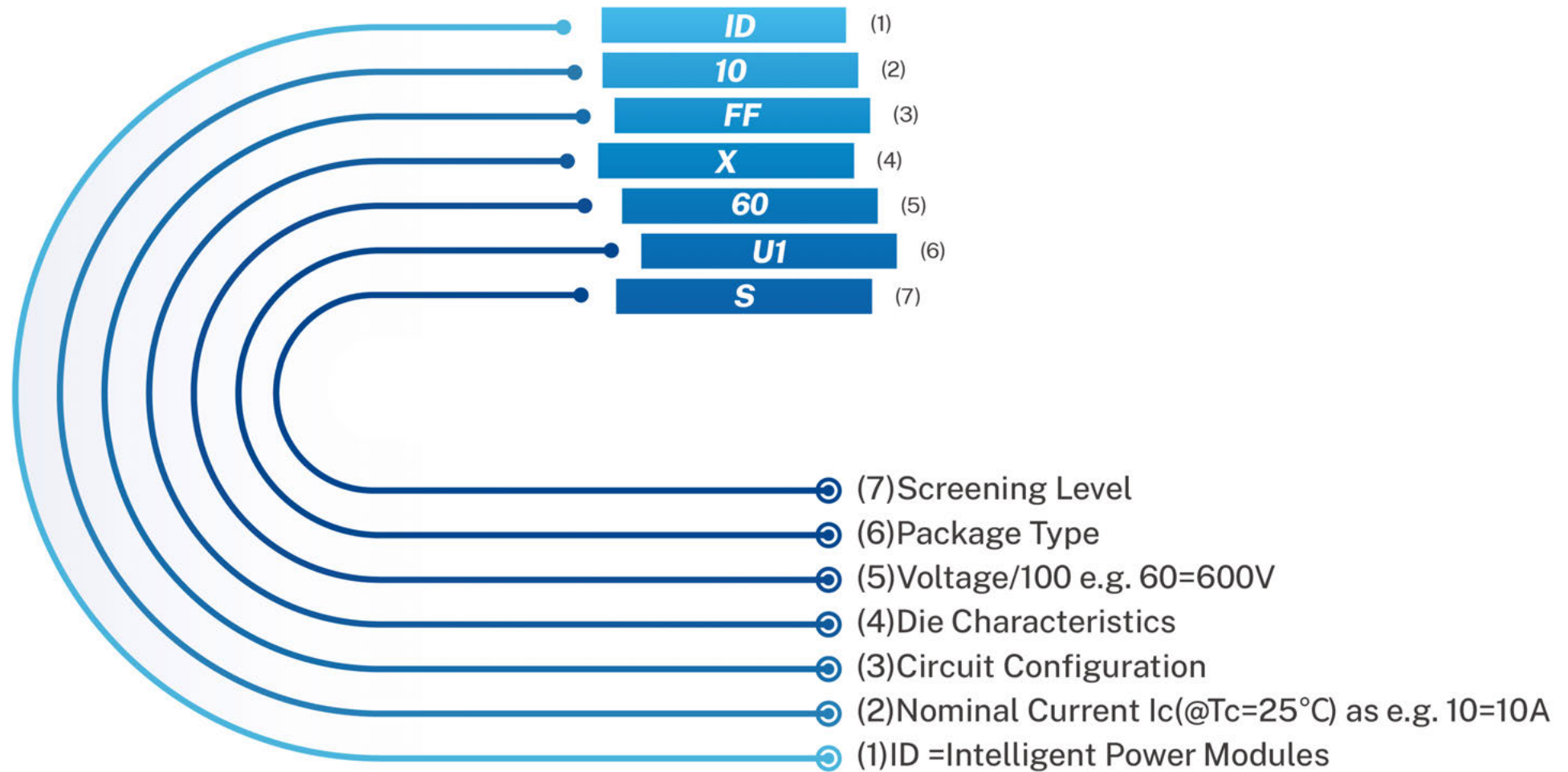

Solar Power

With NTC, Solder pins

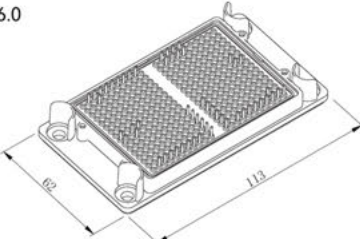
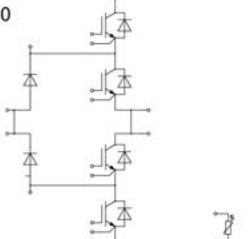
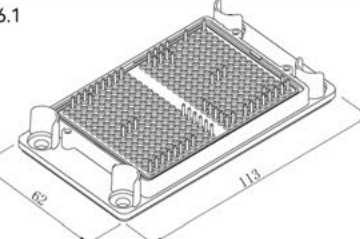
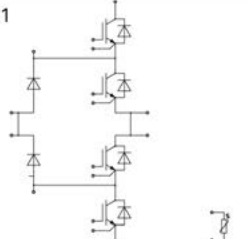
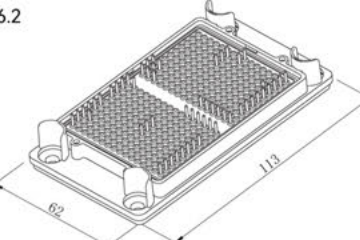
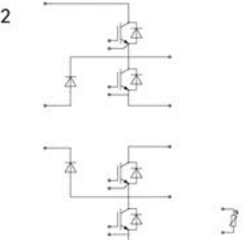
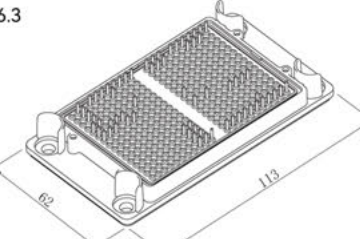
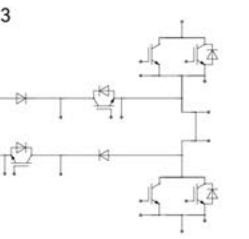
L6 3-level	Dimension[mm]	Ic	750V	1000V		1200V
			A series	X series	A series	A series
L6.0 	L6.0 	600A			GD600MJA100L6S	
					GD600MJA100L6Q	
		650A			GD650MJA100L6S	
					GD650MJA100L6Q	
L6.1 	L6.1 	450A	GD450MMA75L6S			
		500A				GD500MMA120L6S
L6.2 	L6.2 	600A			GD600MHA105L6Q	
					GD600MHA105L6Q_B4	
L6.3 	L6.3 	600A				GD600TLA120L6L
						GD600TLA120L6Q

Solar Power

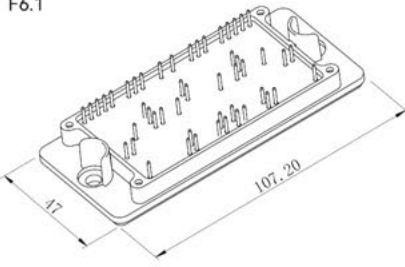
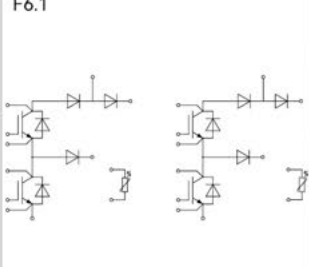
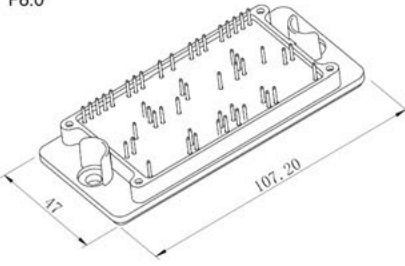
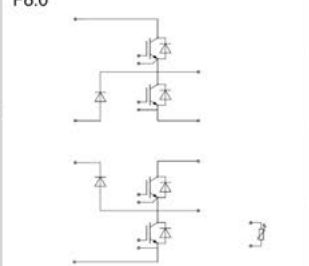
With NTC, Solder pins	F6 boost	Dimension[mm]	Ic	750V	1000V		1200V
				A series	X series	A series	A series
With NTC, Solder pins			200A		GD200DFS100F6S	GD200DFA100F6S	
With NTC, Solder pins	F6 3-level	Dimension[mm]	Ic	750V	1000V		1200V
				A series	X series	A series	A series
With NTC, Solder pins			400A			GD400MJA100F6S	

Automotive SiC

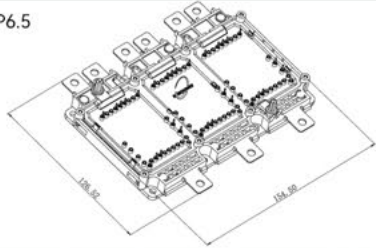
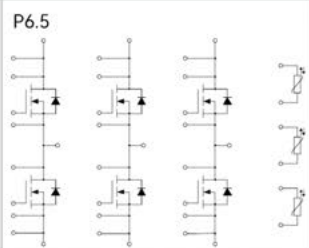
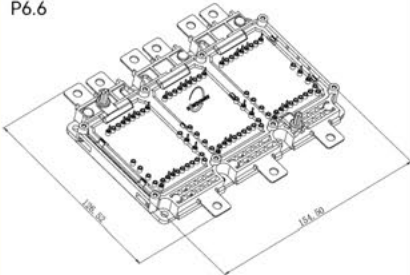
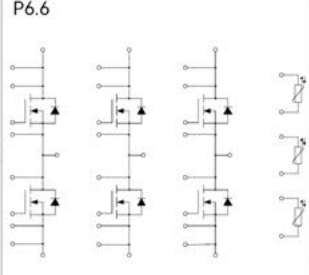
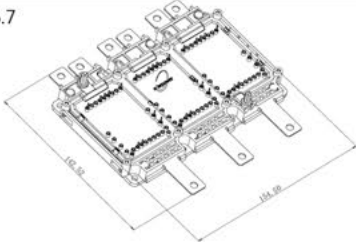
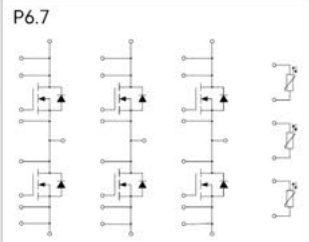
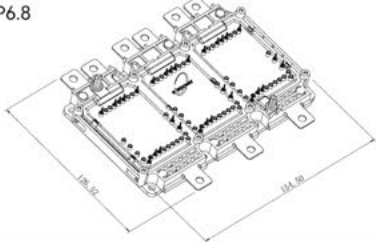
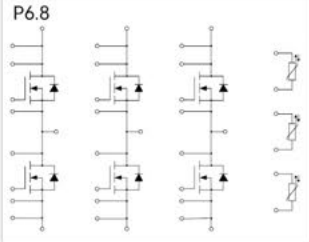
	P6 6-Pack	Dimension[mm]	$R_{DS(on)}$	750V		1200V	
				C series	S series	C series	S series
With NTC, Solder pins			1.25mΩ	MD13HTC75P6HE			
			1.70mΩ	MD17HTC75P6HE			
			2.15mΩ			MD22HTC120P6HE	
			2.83mΩ			MD29HTC120P6HE	
With NTC, Solder pins			1.25mΩ	MD13HTC75P6HET			
			1.70mΩ	MD17HTC75P6HET			
			2.15mΩ			MD22HTC120P6HET	
			2.83mΩ			MD29HTC120P6HET	MD29HTS120P6HET
			3.40mΩ			MD34HTC120P6HET	
			3.00mΩ			MD30HTC120P6HET	
With NTC, Solder pins			2.83mΩ			MD29HTC120P6HELT	
			2.15mΩ			MD22HTC120P6HELT	
With NTC, Press fit pins			2.15mΩ			MD22HTC120P6HEF	
			2.83mΩ			MD29HTC120P6HEF	

Automotive SiC

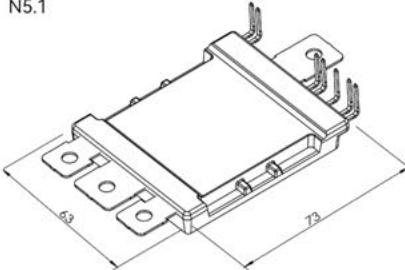
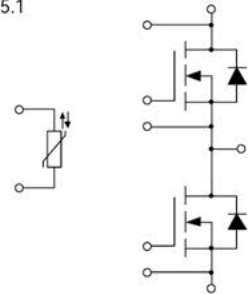
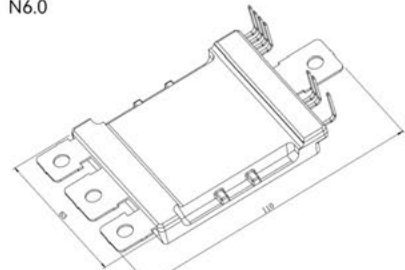
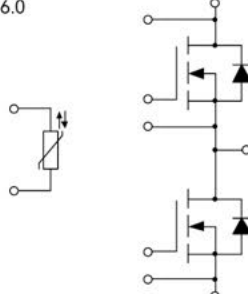
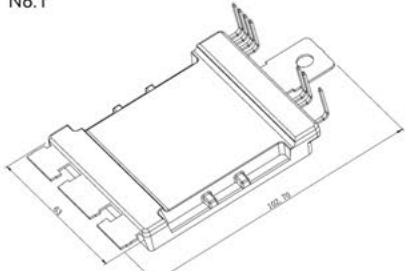
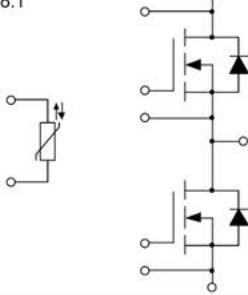
With PTC, Solder pins	N5 2-pack	Dimension[mm]	$R_{DS(on)}$	750V				
				C series	S series			
	N5.1		N5.1 	1.00mΩ	MD10HFC75N5HT	MD10HFS75N5HT		
			1.25mΩ	MD13HFC75N5HT	MD13HFS75N5HT			
With PTC, pins	N6 2-pack	Dimension[mm]	$R_{DS(on)}$	750V		1200V		
				C series	S series	C series	S series	
	N6.0		N6.0 	2.12mΩ			MD22HFC120N6HY	MD22HFS120N6HY
							MD22HFC120N6HT	
N6.1		N6.1 	2.83mΩ			MD29HFC120N6HQY		

Automotive SiC

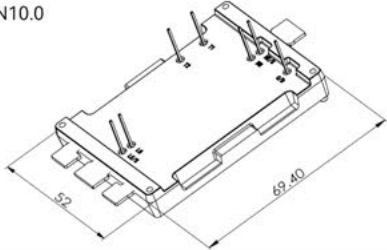
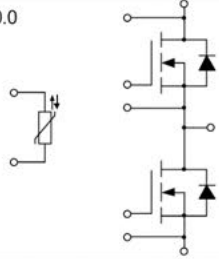
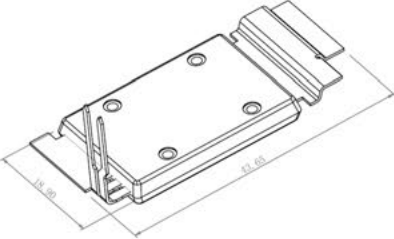
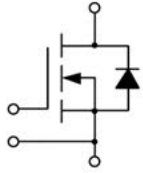
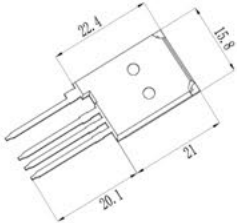
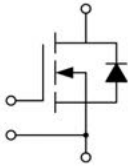
With PTC, pins	N10 2-pack	Dimension[mm]	$R_{DS(on)}$	750V		1200V	
				C series	S series	C series	S series
	N10.0		N10.0 	2.02mΩ			
			2.83mΩ			MD29HFC120N10HY	MD29HFS120N10HY
T-pack	T6 1-pack	Dimension[mm]	$R_{DS(on)}$	750V		1200V	
				C series	S series	C series	S series
	T6.1		T6.1 	5.00mΩ	DM50C08T6	DM50S08T6	
			8.80mΩ			DM88C12T6	DM88S12T6
Without NTC	TO-247PLUS-4L-Single Switch	Dimension[mm]	$R_{DS(on)}$	750V		1200V	
				C series	S series	C series	S series
	T2.2		T2.2 	14mΩ		DM140S08TDRB	
			17mΩ		/		DM170S12TDRB
			40mΩ		/		DM400S12TDRB
			80mΩ		/		DM800S12TDRB

Automotive IGBT

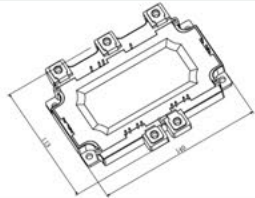
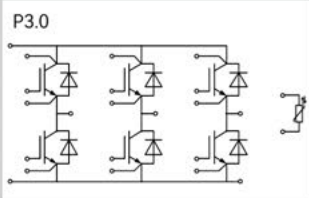
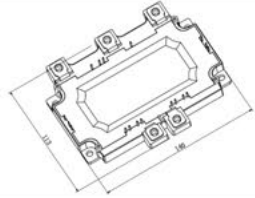
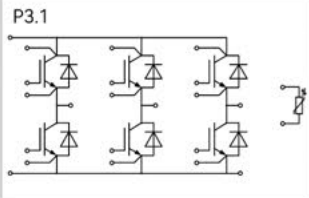
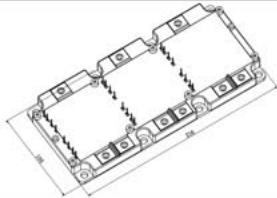
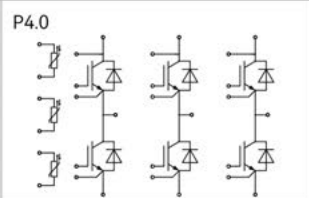
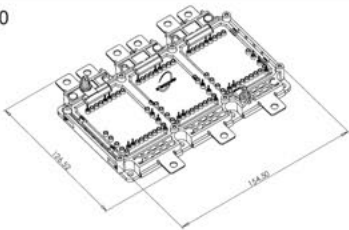
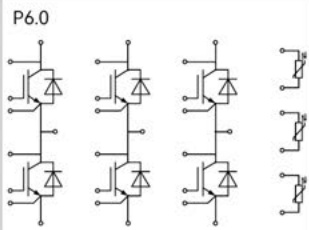
With NTC, Solder pins	P3 6-Pack	Dimension[mm]	Ic	650V		750V		1200V		
				X series	A series	X series	A series	X series	A series	
With NTC, Solder pins			300A	GD300FFX65P3S						
			400A	GD400FFX65P3S		GD400FFX75P3S				
With NTC, Solder pins			200A					GD200FFX120P3H		
			300A	GD300FFX65P3H						
			400A	GD400FFX65P3H		GD400FFX75P3H				
With NTC, Solder pins			400A				GD400HTX120P4SD			
			500A				GD500HTX120P4S			
			800A	GD800HTX75P4S						
With NTC, Solder pin			400A				GD400HTX120P6H			
			600A					GD600HTA120P6H		
			720A					GD720HTA120P6H		
			820A	GD820HTX75P6HB	GD820HTA75P6H					
			950A	GD950HTX75P6HB	GD950HTA75P6H					
			1000A		GD1000HTA75P6H					

Automotive IGBT

With NTC, Solder pins

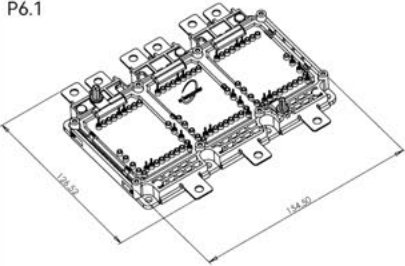
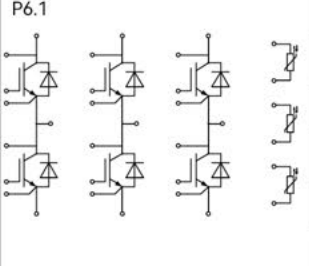
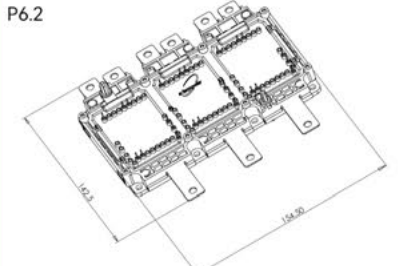
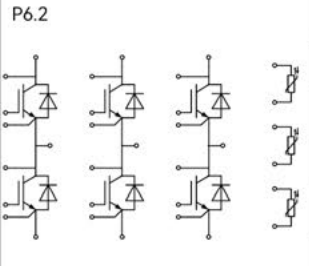
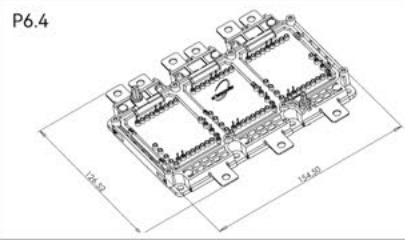
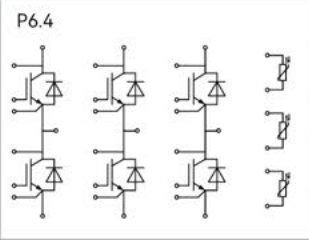
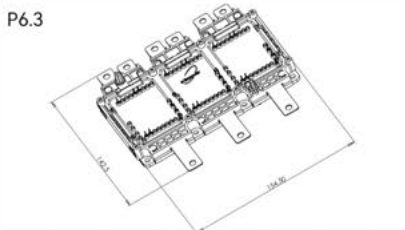
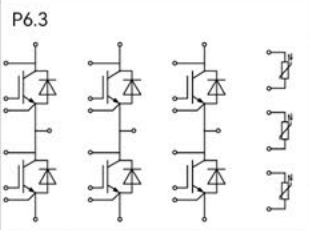
P6 6-Pack	Dimension[mm]	Ic	750V		1200V	
			X series	A series	X series	A series
P6.1 	P6.1 	400A			GD400HTX120P6HT	
		600A				GD600HTA120P6HT
		720A				GD720HTA120P6HT
		820A		GD820HTA75P6HT		
		950A		GD950HTA75P6HT		
		1000A		GD1000HTA75P6HT		
P6.2 	P6.2 	400A				
		600A				GD600HTA120P6HLT
		720A				GD720HTA120P6HLT
		820A		GD820HTA75P6HLT		
		950A		GD950HTA75P6HLT		
		1000A		GD1000HTA75P6HLT		
P6.4 	P6.4 	660A	GD660HTX75P6SB	GD660HTA75P6S		
P6.3 	P6.3 	820A	GD820HTX75P6HLB			
		950A	GD950HTX75P6HLB	GD950HTA75P6HL		

Automotive IGBT

With NTC, Solder pins

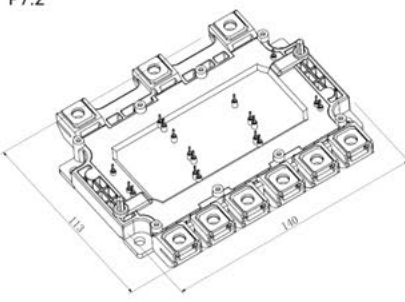
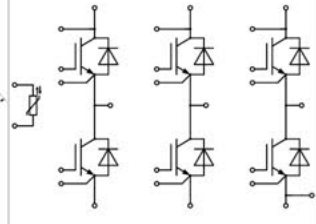
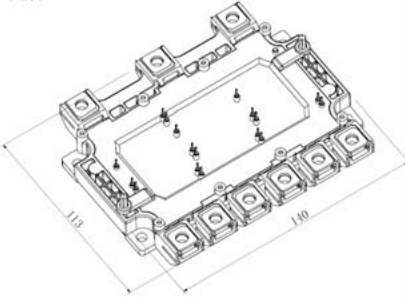
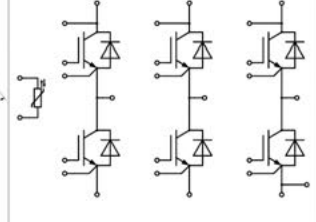
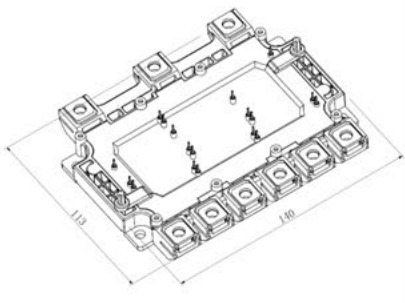
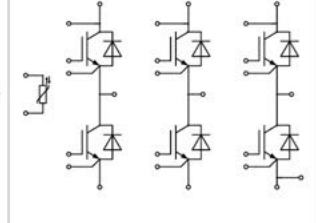
P7 6-Pack	Dimension[mm]	Ic	650V		750V		1200V	
			X series	A series	X series	A series	X series	A series
P7.2 	P7.2 	300A	GD300HTX65P7S					
		400A	GD400HTX65P7S		GD400HTX75P7S			
		500A				GD500HTA75P7S_C		
P7.1 	P7.1 	400A	GD400HTX65P7HN		GD400HTX75P7HN			
		560A			GD560HTX75P7HN			
		660A			GD660HTX75P7HN			
P7.0 	P7.0 	260A			GD260HTX120P7H	GD260HTA75P7H_T		
		400A			GD400HTX75P7H		GD400HTA120P7H_T	
		560A			GD560HTX75P7HB			
		660A			GD660HTX75P7HB	GD660HTA75P7H_T		

Automotive IGBT

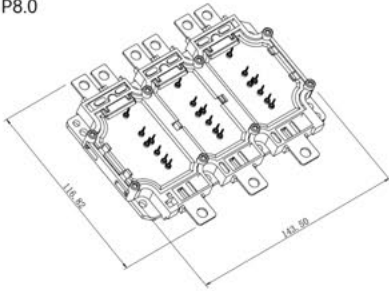
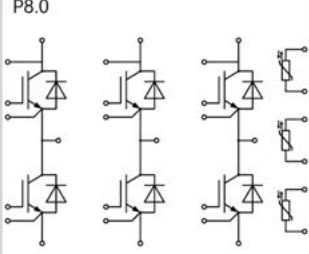
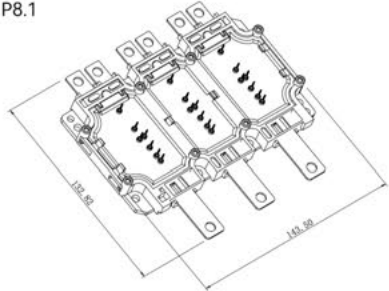
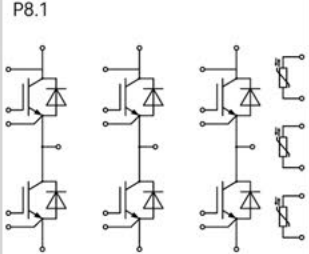
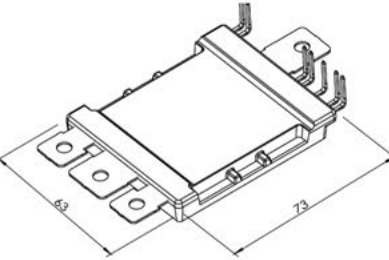
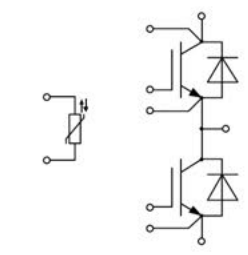
With NTC, Solder pins	P8 6-Pack	Dimension[mm]	Ic	750V		1200V	
				X series	A series	X series	A series
	P8.0			300A			
			650A		GD650HTA75P8HFT		
			630A		GD630HTA75P8HFT		
			400A		GD400HTA75P8HFT		
			480A				GD480HTA120P8HFT
P8.1			300A				GD300HTA120P8HFLT
			650A		GD650HTA75P8HFLT		
			630A		GD630HTA75P8HFLT		
			400A		GD400HTA75P8HFLT		
			480A				GD480HTA120P8HFLT
With NTC, Solder pin	N5 2-pack	Dimension[mm]	Ic	750V			
				X series	A series		
	N5.0			660A	GD660HFX75N5HY	GD660HFA75N5HY	
			1000A		GD1000HFA75N5HT		

Automotive IGBT

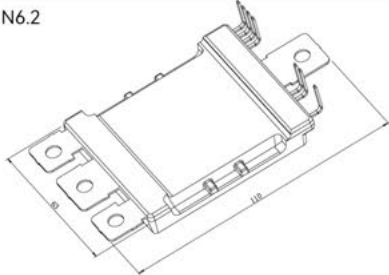
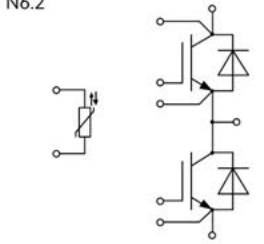
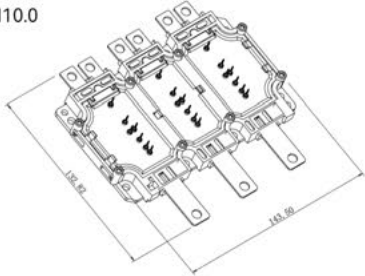
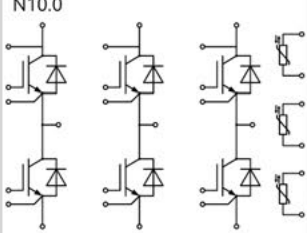
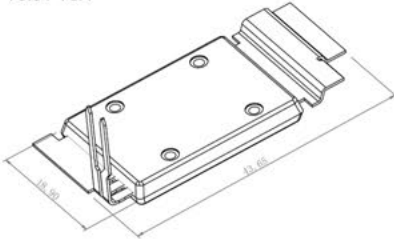
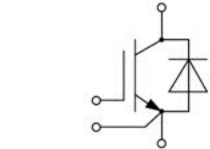
With PTC, pins	N6 2-pack	Dimension[mm]	Ic	750V		1200V	
				X series	A series	X series	A series
With PTC, pins			450A			GD450HFX120N6HY	
			600A				GD600HFA120N6HY
			820A		GD820HFA75N6HY		
			1000A		GD1000HFA75N6HY		
With NTC, pins	N10 2-pack	Dimension[mm]	Ic	750V			
				X series	A series		
With NTC, pins			660A		GD660HFA75N10HY		
			1000A		GD1000HFA75N10HY		
T-pack	T6 Single Switch	Dimension[mm]	Ic	750V		1200V	
				X series	A series	X series	A series
T-pack			200A			DG200X12T6B-U	DG200A12T6B-U
			340A	DG340X08T6B-U	DG340A08T6B-U		

PIM

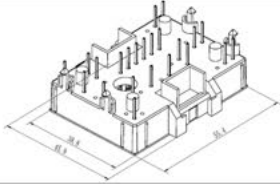
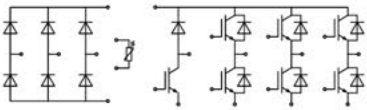
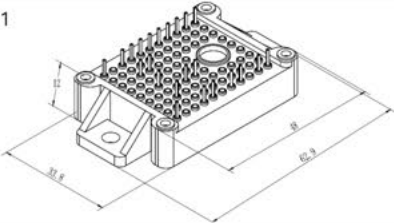
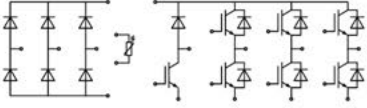
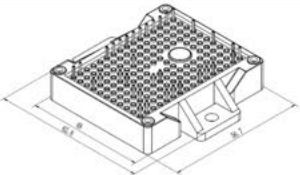
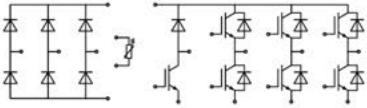
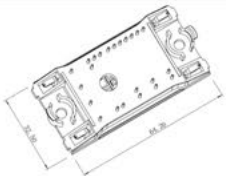
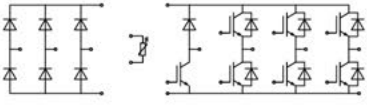
With NTC, Solder pin	L1 PIM	Dimension[mm]	Ic	650V X series	1200V	
					X series	A series
With NTC, Solder pin			10A	GD10PJX65L1S	GD10PJX120L1SA	
			15A	GD15PJX65L1S	GD15PJX120L1SA	
			20A	GD20PJX65L1S		
			30A	GD30PJX65L1S		
With NTC, solder pins			10A	GD10PJX65L2S	GD10PJX120L2SA	GD10PJA120L2S
			15A	GD15PJX65L2S	GD15PJX120L2SA	GD15PJA120L2S
			20A	GD20PJX65L2S		
			25A			GD25PJA120L2S
			30A	GD30PJX65L2S		
With NTC, solder pins			25A		GD25PJX120L3SA	GD25PJA120L3S
			30A	GD30PJX65L3S		
			35A		GD35PJX120L3SA	GD35PJA120L3S
			50A	GD50PJX65L3S		GD50PJA120L3S
With NTC, solder pins			10A	GD10PJX65F1S	GD10PJX120F1S	
			15A	GD15PJX65F1S	GD15PJX120F1S	
			20A	GD20PJX65F1S		
			30A	GD30PJX65F1S		

PIM

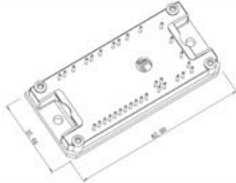
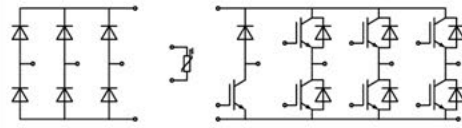
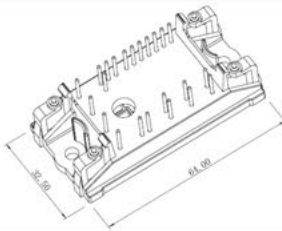
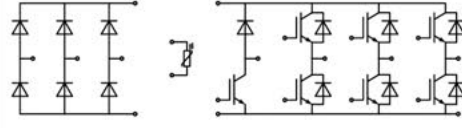
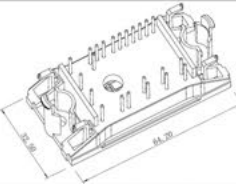
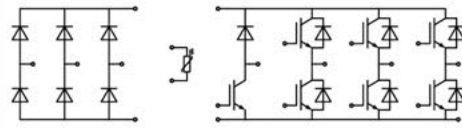
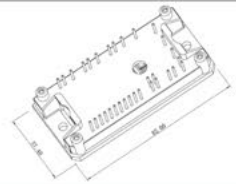
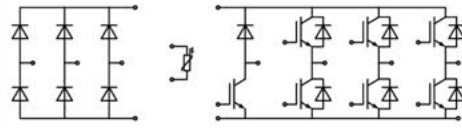
With NTC, Solder pin	F2 PIM	Dimension[mm]	Ic	650V X series	1200V X series
	F2.0		F2.0 	15A 25A 35A	
With NTC, solder pins	F3 PIM	Dimension[mm]	Ic	650V X series	1200V X series
	F3.0		F3.0 	10A 15A 20A 30A	GD10PjX65F3S GD15PjX65F3S GD20PjX65F3S GD30PjX65F3S
With NTC, solder pins	F4 PIM	Dimension[mm]	Ic	650V X series	1200V X series
	F4.0		F4.0 	10A 15A 20A 30A	GD10PjX65F4S GD15PjX65F4S GD20PjX65F4S GD30PjX65F4S
With NTC, solder pins	F5 PIM	Dimension[mm]	Ic	650V X series	1200V X series
	F5.0		F5.0 	15A 25A 35A	

PIM

With NTC, Solder pins

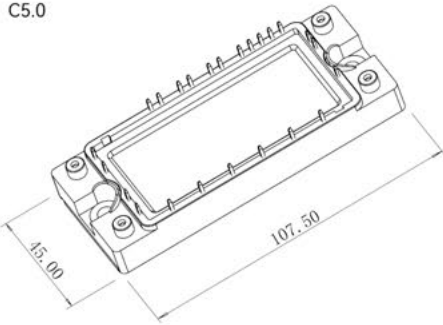
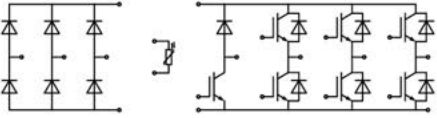
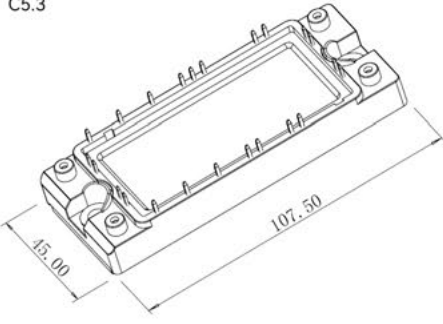
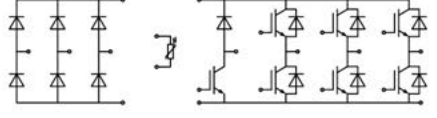
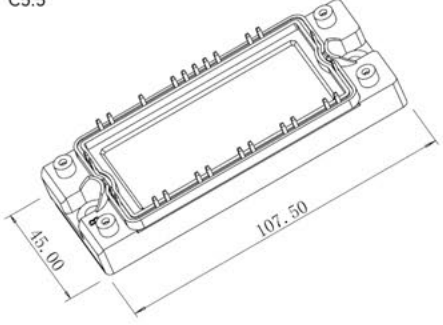
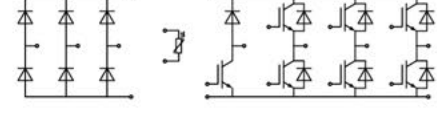
C5 PIM	Dimension[mm]	Ic	650V	1200V	
			X series	X series	A series
	C5.0 	15A		GD15PIX120C5SA	
		25A		GD25PIX120C5SA	
		30A	GD30PIX65C5S		
		40A		GD40PIX120C5SA	
	C5.3 	25A		GD25PIX120C5SNA	GD25PIA120C5SN
		35A		GD35PIX120C5SNA	GD35PIA120C5SN
		50A	GD50PIX65C5SN	GD50PIX120C5SNA	GD50PIA120C5SN
		75A	GD75PIX65C5SN		GD75PIA120C5SN
		100A			GD100PIA120C5SN
	C5.5 	50A	GD50PIX65C5SG	GD50PIX120C5SGA	GD50PIA120C5SG
		75A	GD75PIX65C5SG		GD75PIA120C5SG

PIM

With NTC, Solder pins

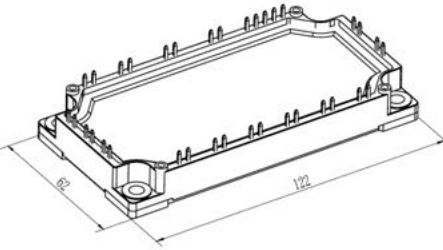
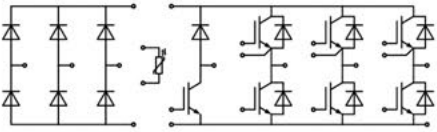
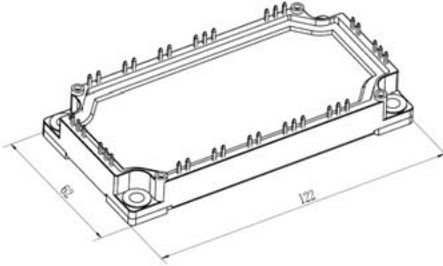
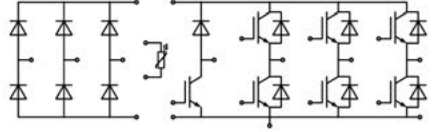
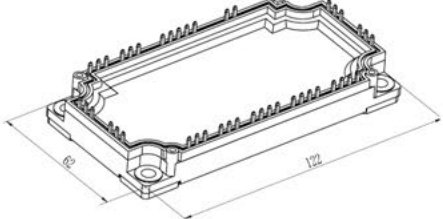
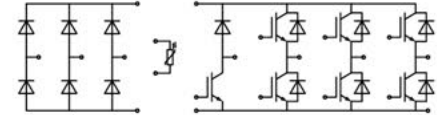
C6 PIM	Dimension[mm]	Ic	1200V		1700V
			X series	A series	X series
C6.0 	C6.0 	50A	GD50PIX120C6SA		GD50PIX170C6S
		75A	GD75PIX120C6SA		GD75PIX170C6S
		100A			
		150A			
		200A			
C6.3 	C6.3 	50A	GD50PIX120C6SNA		
		75A	GD75PIX120C6SNA	GD75PIA120C6SN	
		100A	GD100PIX120C6SNA	GD100PIA120C6SN	
		150A	GD150PIX120C6SNA	GD150PIA120C6SN	
		200A		GD200PIA120C6SN	
C6.6 	C6.6 	50A	GD50PIX120C6SGA	GD50PIA120C6SG	
		75A	GD75PIX120C6SGA	GD75PIA120C6SG	
		100A	GD100PIX120C6SGA	GD100PIA120C6SG	
		150A	GD150PIX120C6SGA	GD150PIA120C6SG	

6-Pack

With NTC, Solder pin	L2 6-PACK	Dimension[mm]	Ic	650V X series	1200V	
					X series	A series
With NTC, Solder pin			10A		GD10FSX120L2SA	
			15A		GD15FSX120L2SA	
			20A	GD20FSX65L2S		
			25A		GD25FSX120L2SA	GD25FSA120L2S
			30A	GD30FSX65L2S		
			35A		GD35FSX120L2SA	GD35FSA120L2S
			50A	GD50FSX65L2S		GD50FSA120L2S
			With NTC, Solder pin			50A
75A		GD75FSX120L3SA				GD75FSA120L3S
100A						GD100FSA120L3S
With NTC, Solder pin			10A	GD10FSX65L4SN	GD10FSX120L4SNA_B37	
			15A	GD15FSX65L4SN		
			20A	GD20FSX65L4SN		

6-Pack

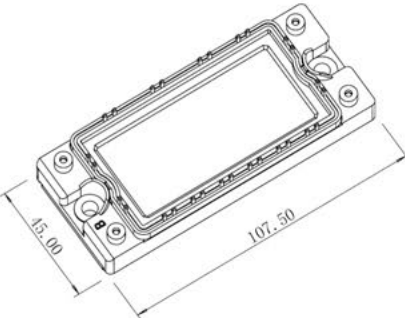
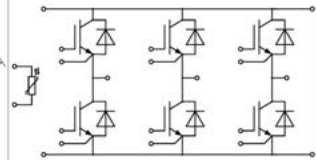
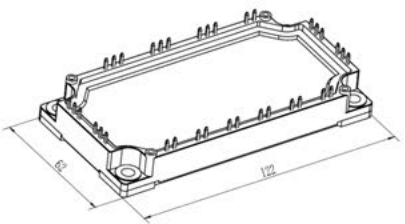
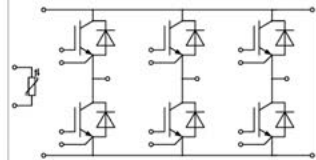
With NTC, Solder pin	C5 6-pack	Dimension[mm]	Ic	650V	1200V		1700V
				X series	X series	A series	X series
	C5.2		50A	GD50FFX65C5S	GD50FFX120C5SA	GD50FFA120C5S	GD50FFX170C5S
			75A	GD75FFX65C5S	GD75FFX120C5SA	GD75FFA120C5S	
			100A	GD100FFX65C5S	GD100FFX120C5SA	GD100FFA120C5S	
			150A			GD150FFA120C5S	
With NTC, Solder pin	C6 6-pack	Dimension[mm]	Ic	1200V		1700V	
				X series	A series	X series	
	C6.2		50A	GD50FFX120C6SA			
			75A	GD75FFX120C6SA			GD75FFX170C6S
			100A	GD100FFX120C6SA			GD100FFX170C6S
			150A	GD150FFX120C6SA	GD150FFA120C6S	GD150FFX170C6S	
			200A	GD200FFX120C6SA	GD200FFA120C6S		
			300A		GD300FFA120C6S		

All In One

With NTC, Solder pin

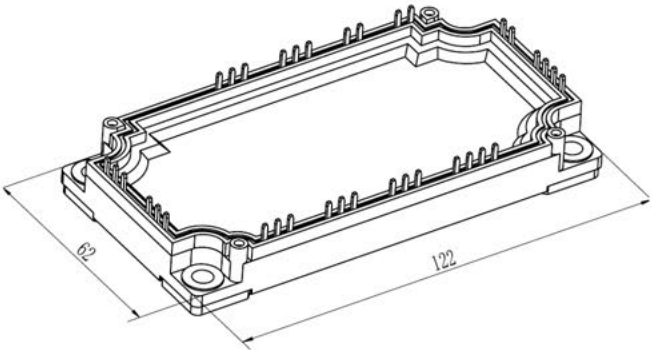
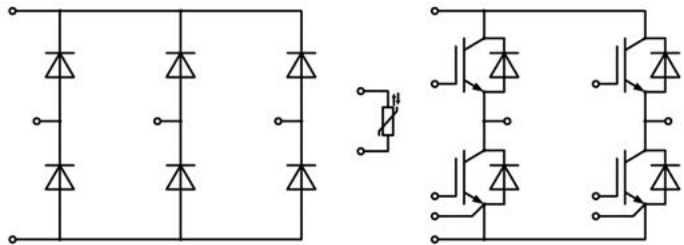
C6 ALL IN ONE	Dimension[mm]	Ic	1700V
			X series
C6.12 	C6.12 	50A	GD50PFX170C6SG
		75A	GD75PFX170C6SG
		100A	GD100PFX170C6SG
		150A	GD150PFX170C6SG
		200A	GD200PFX170C6SG

2-Pack

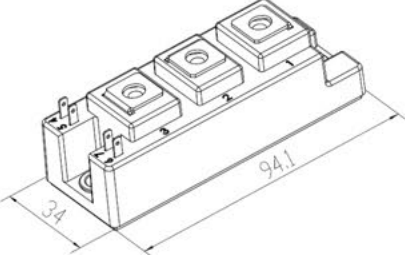
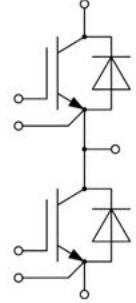
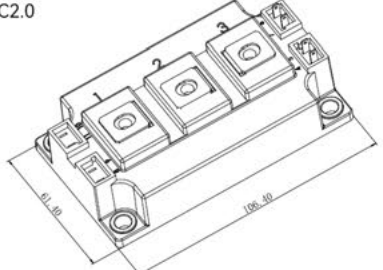
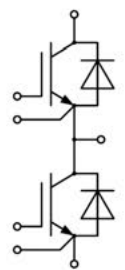
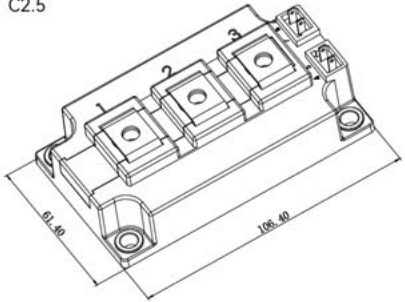
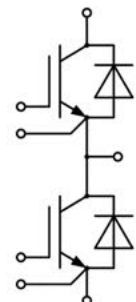
Without NTC	C1 2-Pack	Dimension[mm]	Ic	650V X series	1200V X series	1700V X series
	C1.0		C1.0 	50A 75A 100A 150A 200A	GD50HFX65C1S GD75HFX65C1S GD100HFX65C1S GD150HFX65C1S GD200HFX65C1S	GD50HFX120C1SA GD75HFX120C1SA GD100HFX120C1SA GD150HFX120C1SA
Without NTC	C2 2-Pack	Dimension[mm]	Ic	650V X series	1200V X series	1700V A series X series
	C2.0		C2.0 	150A 200A 300A 400A 450A 600A	GD200HFX65C2S GD300HFX65C2S GD400HFX65C2S GD450HFX65C2S GD600HFX65C2S	GD150HFX120C2SA GD200HFX120C2SA GD300HFX120C2SA GD400HFX120C2SA GD450HFX120C2SA GD600HFX120C2SA
C2.5		C2.5 	150A 200A 300A 400A 450A 600A 800A		GD150HFX120C2SA_B20 GD200HFX120C2SA_B20 GD300HFX120C2SA_B20 GD400HFX120C2SA_B20 GD450HFX120C2SA_B20 GD600HFX120C2SA_B20	GD150HFA120C2S_B20 GD200HFA120C2S_B20 GD300HFA120C2S_B20 GD400HFA120C2S_B20 GD600HFA120C2S_B20 GD800HFA120C2S_B20

2-Pack

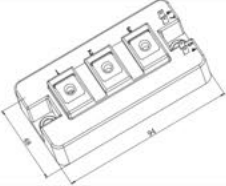
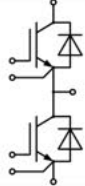
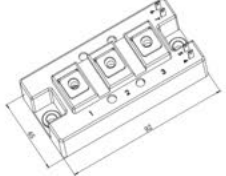
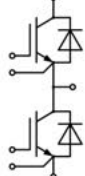
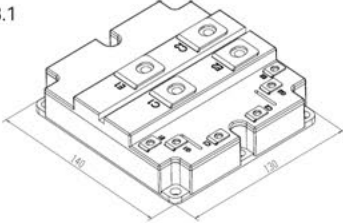
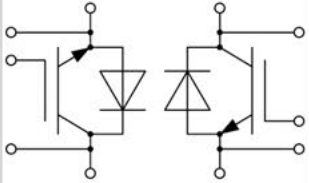
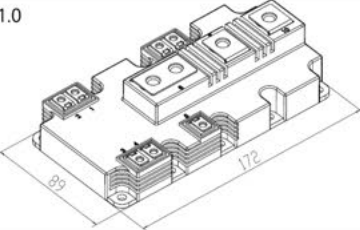
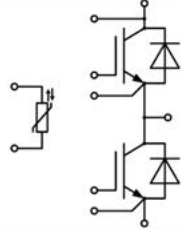
Without NTC	C8 2-Pack	Dimension[mm]	Ic	650V X series	1200V X series	1700V X series
	C8.0		C8.0 	150A 200A 300A 400A	GD200HFX65C8S GD300HFX65C8S GD400HFX65C8S	GD150HFX120C8SA GD200HFX120C8SA
C8.1		C8.1 	150A 200A 300A 400A	GD200HFX65C8SN GD300HFX65C8SN GD400HFX65C8SN	GD150HFX120C8SNA GD200HFX120C8SNA	
Without NTC	C3 2-Pack	Dimension[mm]	Ic	650V X series	1200V X series	
	C3.1		C3.1 	800A 1200A 1600A 2400A		GD800HFX170C3S GD1200HFX170C3S
Without NTC	P1 2-Pack	Dimension[mm]	Ic	1200V X series	1700V X series	
	P1.0		P1.0 	450A 600A 650A 900A	GD450HFX120P1SA GD600HFX120P1SA GD900HFX120P1SA	GD650HFX170P1S

2-Pack

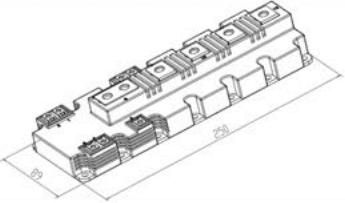
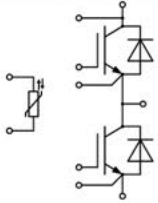
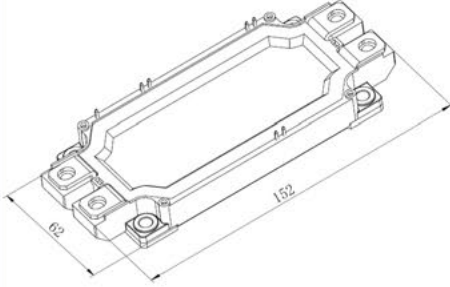
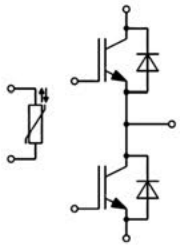
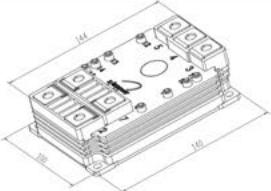
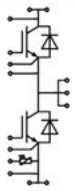
With NTC	P2 2-Pack	Dimension[mm]	Ic	1200V X series	1700V X series		
	P2.0		P2.0 	1000A 1400A	GD1400HFX120P2SA	GD1000HFX170P2S GD1400HFX170P2S	
With NTC, Solder pins	C6.1 2-Pack	Dimension[mm]	Ic	1200V		1700V	
	C6.1	C6.1 	C6.1 	X series	A series	X series	A series
			150A	GD150HFX120C6SA			
			225A	GD225HFX120C6SA		GD225HFX170C6S	
			300A	GD300HFX120C6SA	GD300HFA120C6S	GD300HFX170C6S	GD300HFA170C6S
			450A	GD450HFX120C6SA	GD450HFA120C6S	GD450HFX170C6S	GD450HFA170C6S
			600A	GD600HFX120C6SA	GD600HFA120C6S	GD600HFX170C6S	GD600HFA170C6S
			750A		GD750HFA120C6S		GD750HFA170C6S
			800A		GD800HFA120C6SD		GD800HFA170C6S
			900A		GD900HFA120C6S		GD900HFA170C6S
		1000A		GD1000HFA120C6S			
With NTC	V6 Half Bridge	Dimension[mm]	Ic	1200V X series	1700V L series		
	V6.0	V6.0 	V6.0 	450A			
			1200A	GD1200HFX120V6S	GD1200HFL170V6S		
			1800A	GD1800HFX120V6S	GD1800HFL170V6S		

1-Pack

Without NTC

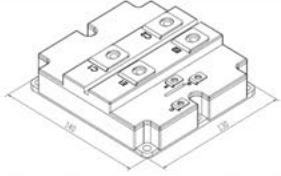
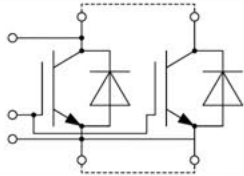
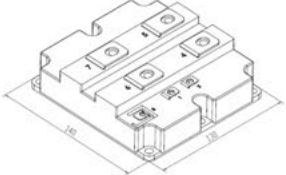
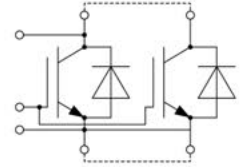
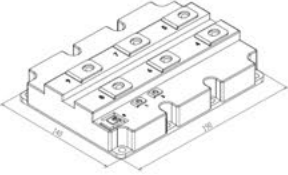
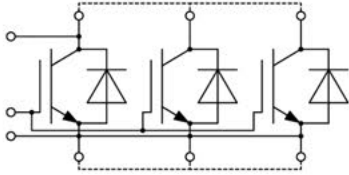
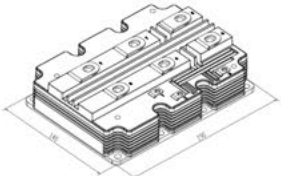
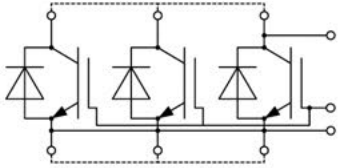
C3 1-Pack		Dimension[mm]	Ic	1200V X series	1700V X series
C3.0			800A		
			1200A		
			1600A		GD1600SGX170C3S
			2400A		
C3.2 1-Pack		Dimension[mm]	Ic	1200V X series	1700V X series
C3.2			800A		
			1200A		
			1600A		
			2400A		GD2400SGX170C3SN
C4 1-Pack		Dimension[mm]	Ic	1200V X series	1700V X series
C4.0			2400A		GD2400SGX170C4S
			3600A		GD3600SGX170C4S
V4 Single		Dimension[mm]	Ic	4500V L series	
V4.0			450A		
			600A		
			800A	GD800SGL450V4S	
			1200A	GD1200SGL450V4S	

3-Level

With NTC, Solder pins	L3 3-Level	Dimension[mm]	Ic	650V X series	1200V Q series
	L3.3		L3.3 	75A 100A 150A	GD75MLX65L3S GD100MLX65L3S GD150MLX65L3S
L3.4		L3.4 	100A 200A		GD100TLQ120L3S GD200TLQ120L3S
With NTC, Solder pins	C6.1 3-level	Dimension[mm]	Ic	1200V	
				X series	A series
C6.15		C6.15 	300A 450A 600A	GD300MNX120C6SA GD300MPX120C6SA GD450MNX120C6SA GD450MPX120C6SA GD600MNX120C6SA GD600MPX120C6SA	
C6.15		C6.15 	750A 900A		GD750MNA120C6S GD750MPA120C6S GD900MNA120C6S GD900MPA120C6S

Discrete Device

	TO-247-3L-Single Switch	Dimension[mm]	Ic	650V	750V	1200V	
				X series	A series	X series	A series
Without NTC			10A			DG10X12T2	DG10A12TASS
			15A			DG15X12T2	DG15A12TASS
			25A			DG25X12T2	DG25A12TASS
							DG25A12TAFS
			30A	DG30X07T2	DG30A08TALS		
					DG30A08TAFS		
			40A		DG40A08TALS	DG40X12T2	DG40A12TASS
					DG40A08TAFS		DG40A12TALD
				DG40A12TAFS			
	50A	DG50X07T2	DG50A08TALS		DG50A12TASS		
			DG50A08TAFS		DG50A12TAFS		
	75A	DG75X07T2L	DG75A08TALS				
			DG75A08TAFS				
	TO-247PLUS-4L-Single Switch	Dimension[mm]	Ic	650V	750V	1200V	
				X series	A series	X series	A series
Without NTC			40A				
			50A				
			75A				
			100A		DG100A08TDFS		DG100A12TDFS
			120A		DG120A08TDFS		DG120A12TDFS
			140A				DG140A12TDFS
			160A		DG160A08TDFS		
			200A				

Discrete Device

Without NTC	TO-247PUS-3L-Single Switch	Dimension[mm]	Ic	650V	750V	1200V	
				X series	A series	X series	A series
	TO-247PLUS-3L	TO-247PLUS-3L	40A				DG40A12TCSS
							DG40A12TCFS
			50A			DG50X12T2	DG50A12TCSS
							DG50A12TCFS
			75A			DG75X12T2	DG75A12TCSS
							DG75A12TCFS
			100A	DG100X07T2	DG100A08TCLS		DG100A12TCSS
					DG100A08TCFS		DG100A12TCFS
			120A		DG120A08TCSS		
				DG120X07T2	DG120A08TCLS		DG120A12TCFS
					DG120A08TCFS		
			140A				DG140A12TCFS
			160A	DG160X07T2	DG160A08TCLS		
					DG160A08TCFS		
			200A		DG200A08TCSS		

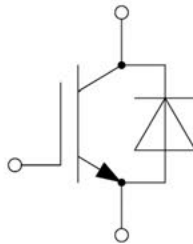
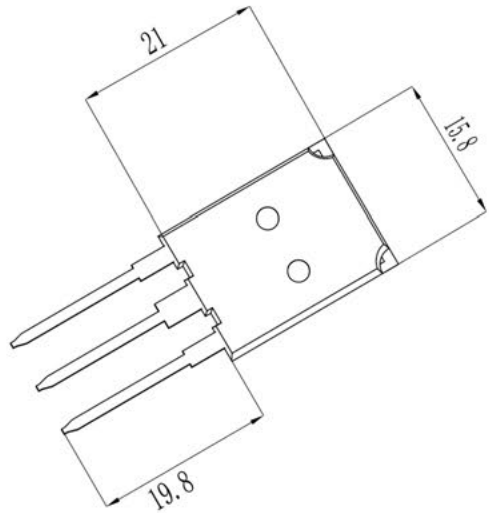

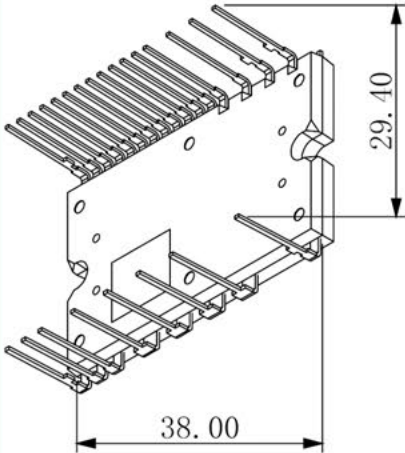
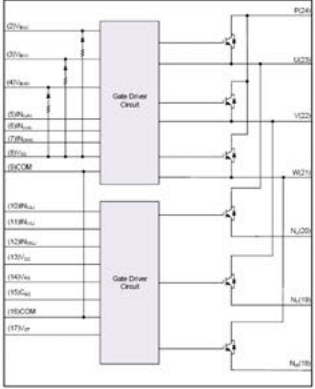
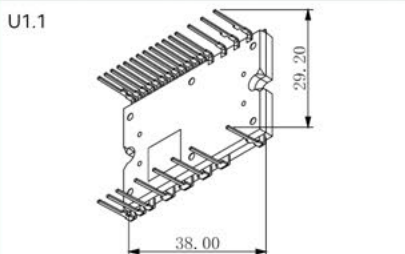
U1	Dimension[mm]	Fo duration selection	V(temp) out	OT protection	UV protection	Short pin	Ic	600V	700V		
								X series	X series		
U1.0 	U1.0 	-	-	-	√	-	10A	ID10FFX60U1S			
		-	-	-	√	-	15A	ID15FFX60U1S			
		-	-	-	√	-	20A	ID20FFX60U1S			
		-	-	-	√	-	30A	ID30FFX60U1S			
		-	-	-	√	-	35A	ID35FFX60U1S			
		-	√	-	√	-	10A	ID10FFX60U1S_A			
		-	√	-	√	-	15A	ID15FFX60U1S_A			
		-	√	-	√	-	20A	ID20FFX60U1S_A			
		-	√	-	√	-	30A	ID30FFX60U1S_A			
		-	√	-	√	-	35A	ID35FFX60U1S_A			
		-	√	√	√	-	10A	ID10FFX60U1S_B			
		-	√	√	√	-	15A	ID15FFX60U1S_B			
		-	√	√	√	-	20A	ID20FFX60U1S_B			
		-	√	√	√	-	30A	ID30FFX60U1S_B			
		-	√	√	√	-	35A	ID35FFX60U1S_B			
		U1.1 		-	√	-	√	√	10A	ID10FFX60U1S_D	
				-	√	-	√	√	15A	ID15FFX60U1S_D	
-	√			-	√	√	20A	ID20FFX60U1S_D			
-	√			-	√	√	30A	ID30FFX60U1S_D			
-	√			-	√	√	35A	ID35FFX60U1S_D			

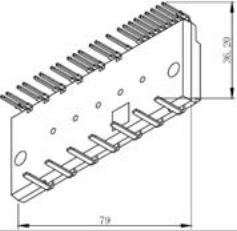
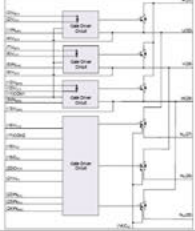
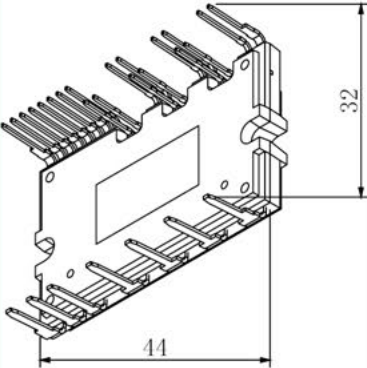
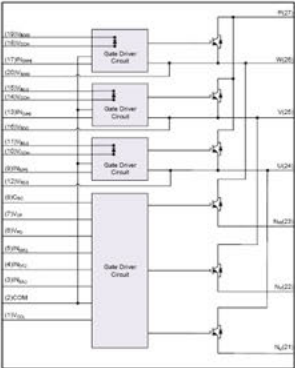
Without NTC	U2	Dimension[mm]	Fo duration selection	V(temp) out	OT protection	UV protection	Short pin	Ic	600V X series	700V X series
		U2.0		-	√	-	√	-	50A	ID50FFX60U2S_A
-				√	-	√	-	75A	ID75FFX60U2S_A	
Without NTC	U3	Dimension[mm]	Fo duration selection	V(temp) out	OT protection	UV protection	Short pin	Ic	600V X series	700V X series
		U3.0		√	-	-	√	-	15A	ID15FFX60U3S
√				-	-	√	-	20A	ID20FFX60U3S	
√				-	-	√	-	30A	ID30FFX60U3S	
√				-	-	√	-	40A	ID40FFX60U3S	
√				-	-	√	-	50A	ID50FFX60U3S	
-				√	-	√	-	15A	ID15FFX60U3S_A	
-				√	-	√	-	20A	ID20FFX60U3S_A	
-				√	-	√	-	30A	ID30FFX60U3S_A	ID30FFX70U3S_A
-				√	-	√	-	40A	ID40FFX60U3S_A	ID40FFX70U3S_A
-				√	-	√	-	50A	ID50FFX60U3S_A	ID50FFX70U3S_A
-				√	√	√	-	15A	ID15FFX60U3S_B	
-				√	√	√	-	20A	ID20FFX60U3S_B	
-				√	√	√	-	30A	ID30FFX60U3S_B	
-				√	√	√	-	40A	ID40FFX60U3S_B	
-	√	√	√	-	50A	ID50FFX60U3S_B				

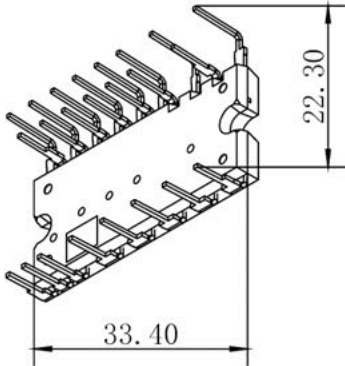
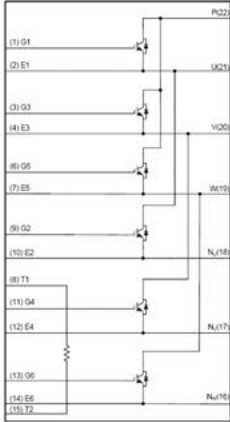
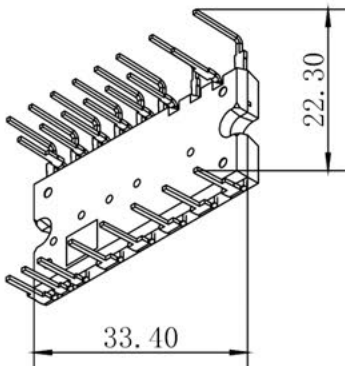
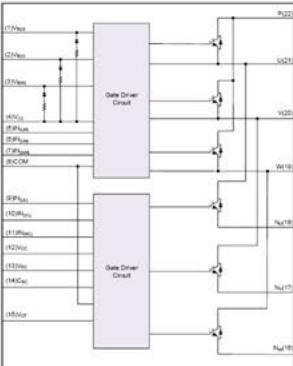
	U4	Dimension[mm]	Fo duration selection	V(temp) out	OT protection	UV protection	Short pin	Ic	600V	700V	
									X series	X series	
With NTC	U4.0 	U4.0 	-	-	-	-	-	5A	GD05FFX60U4SS		
			-	-	-	-	-	10A	GD10FFX60U4SS		
	U5	Dimension[mm]	Fo duration selection	V(temp) out	OT protection	UV protection	Short pin	Ic	600V	700V	
									X series	X series	
Without NTC	U5.0 	U5.0 	-	√	-	√	-	5A	ID05FFX60U5SS		
			-	√	-	√	-	10A	ID10FFX60U5SS		

Package Outlines, mm

Solar Power

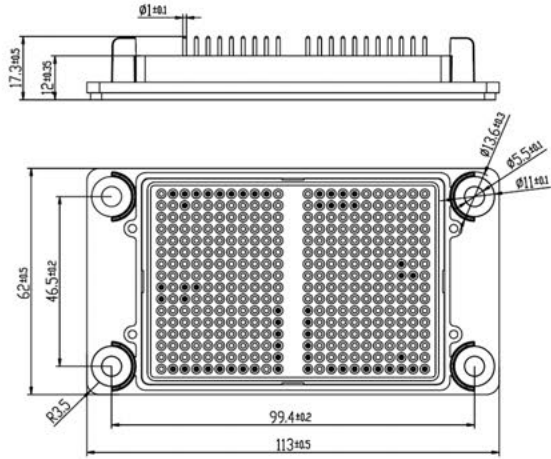

L6.0

Solar Power

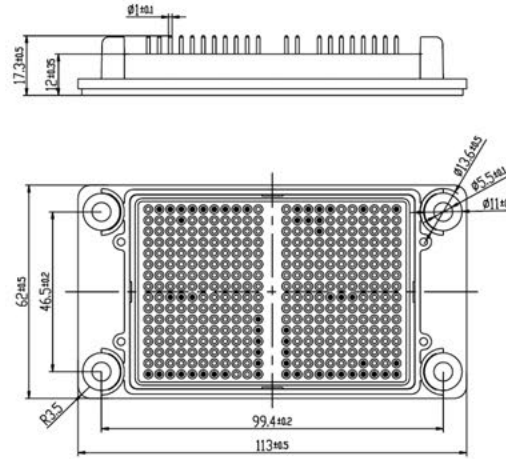

L6.1

Solar Power

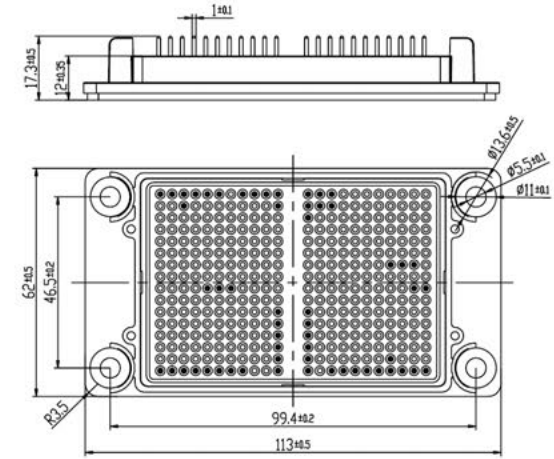

L6.2

Solar Power

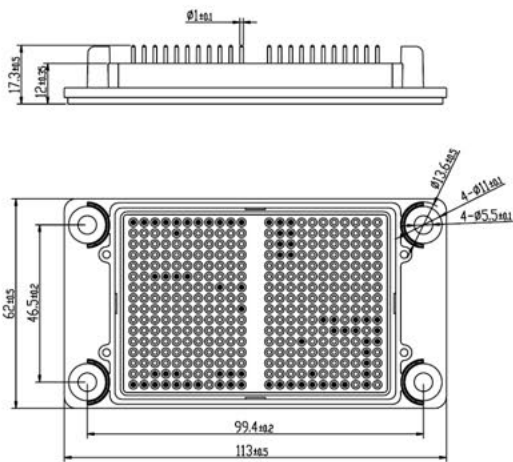

L6.3

Solar Power

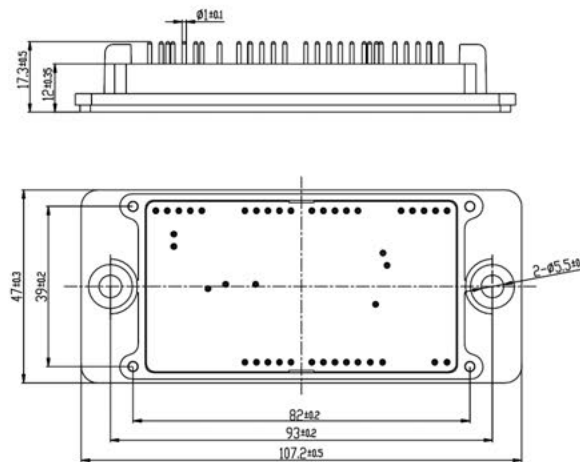

F6.0

Solar Power

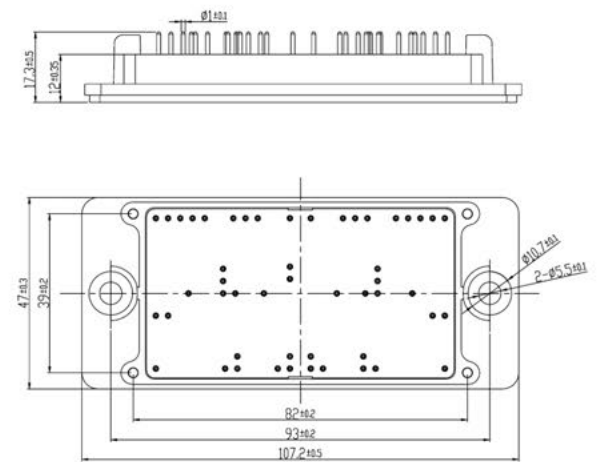

F6.1

Package Outlines, mm

Automotive SiC

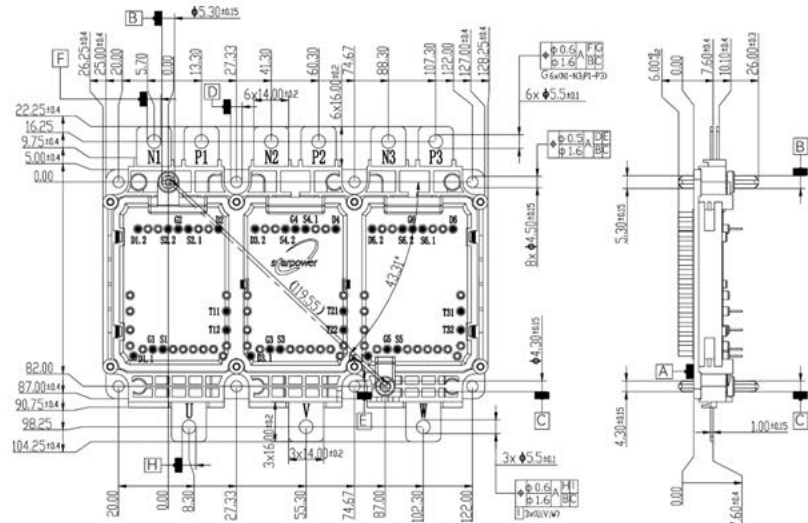

P6.5

Automotive SiC

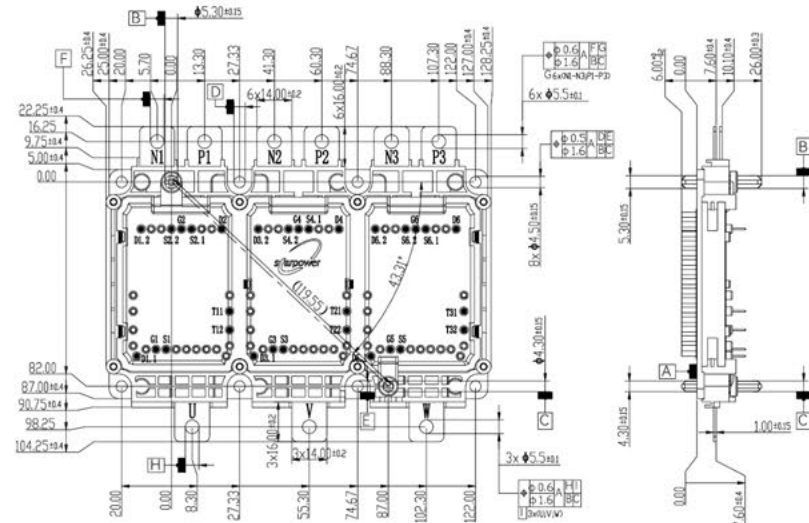

P6.6

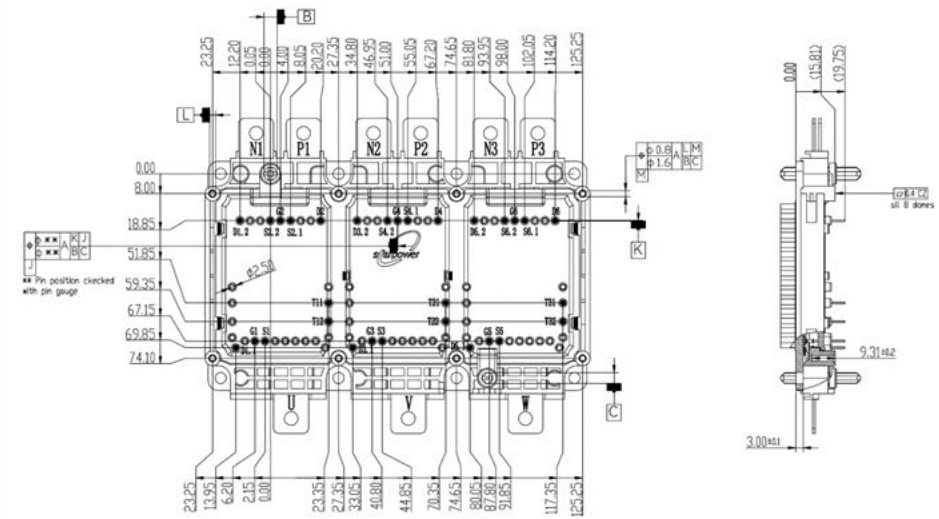
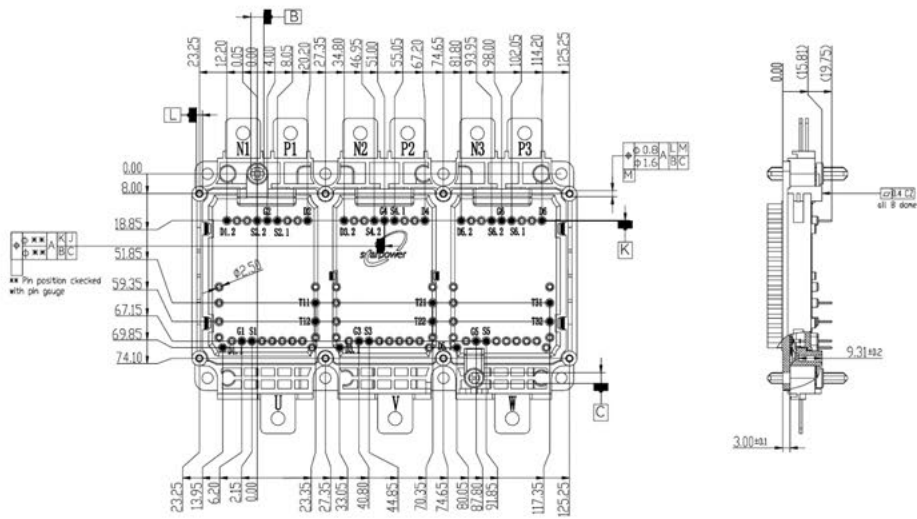

Package Outlines, mm

Automotive SiC

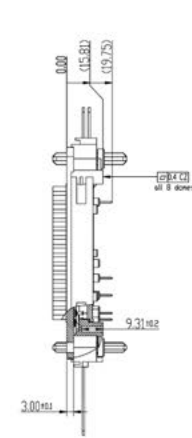
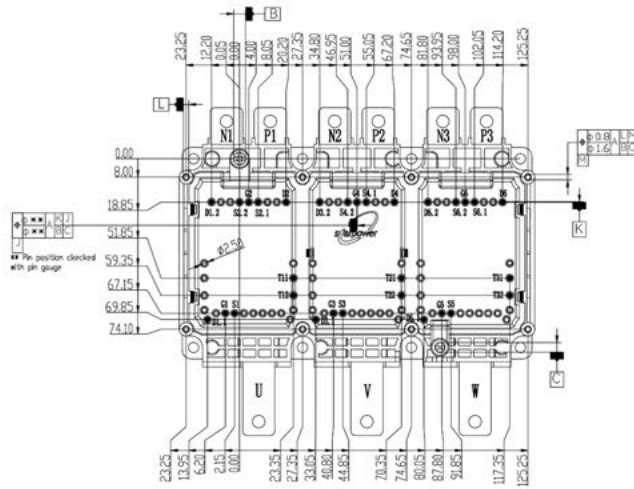
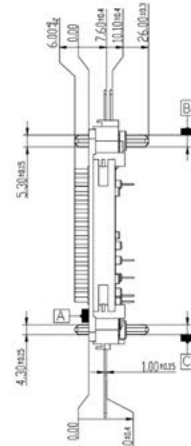
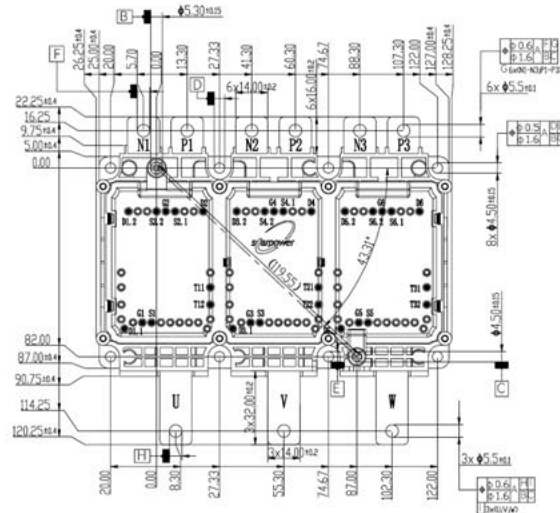

P6.7

Automotive SiC

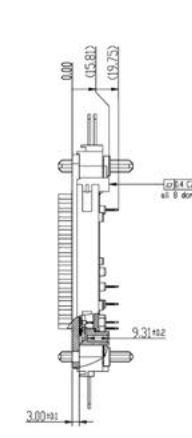
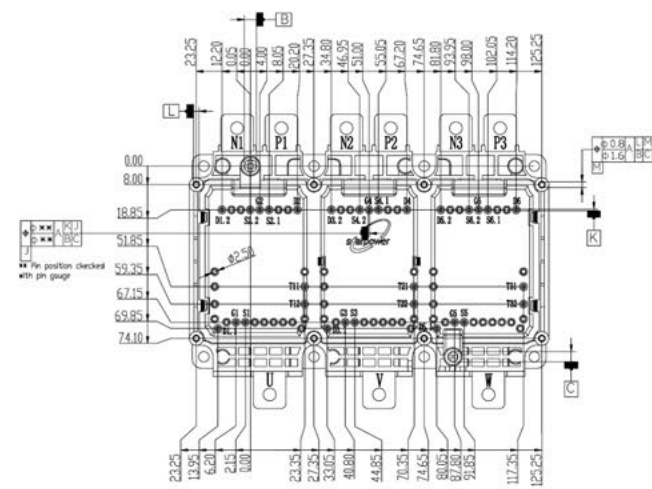
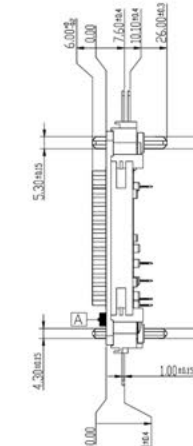
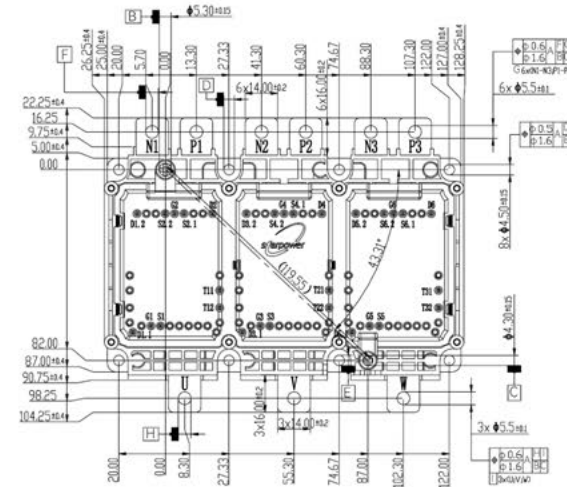

P6.8

Package Outlines, mm

Automotive IGBT

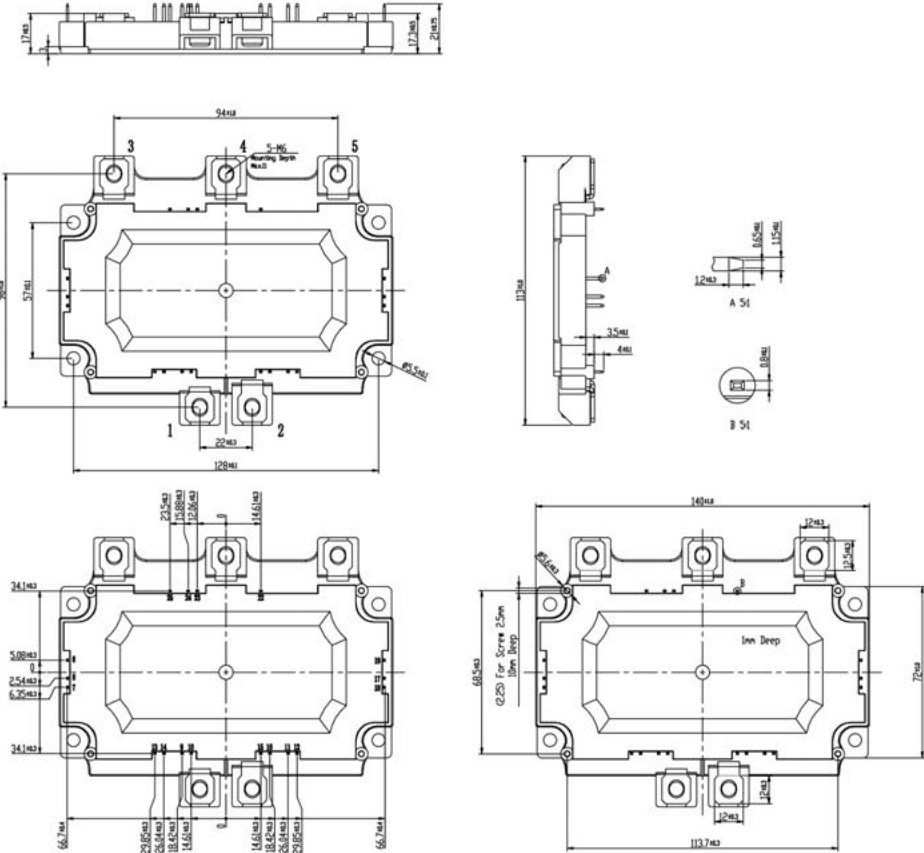

P3.0

Automotive IGBT

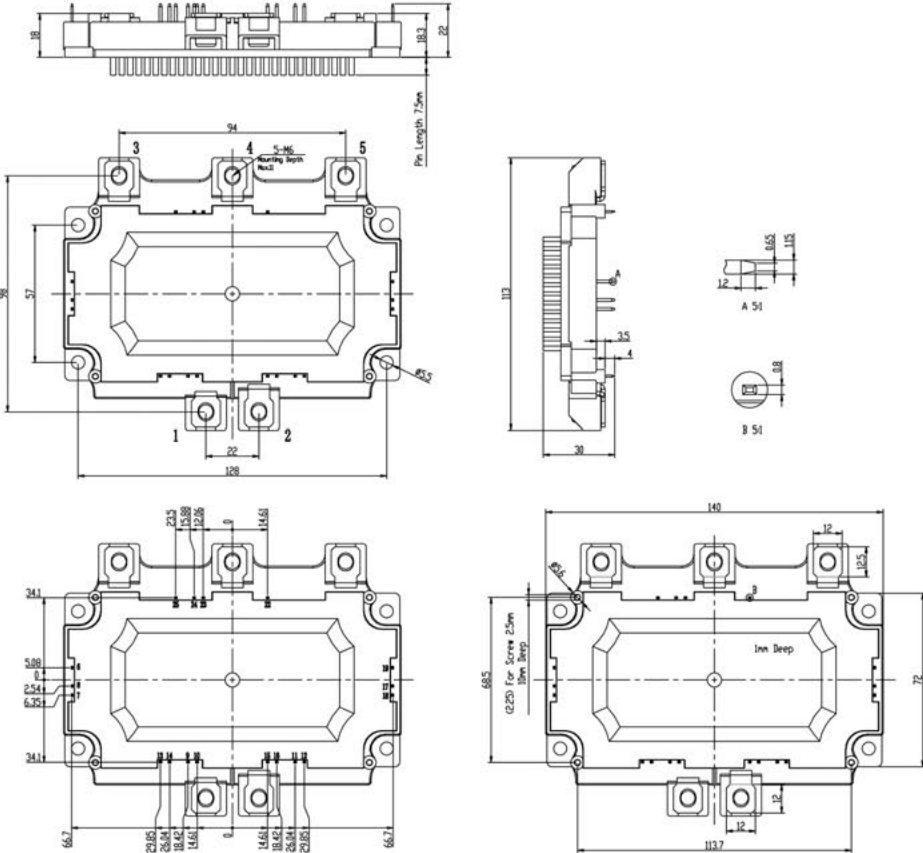

P3.1

Package Outlines, mm

Automotive IGBT

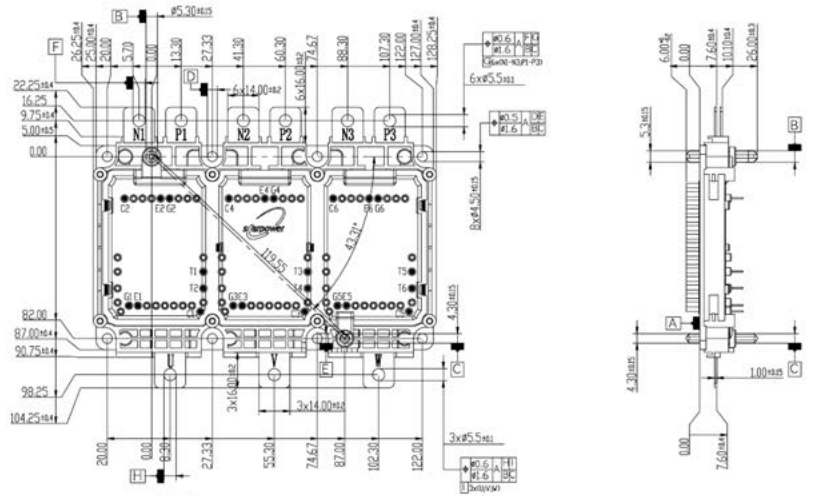

P6.1

Automotive IGBT

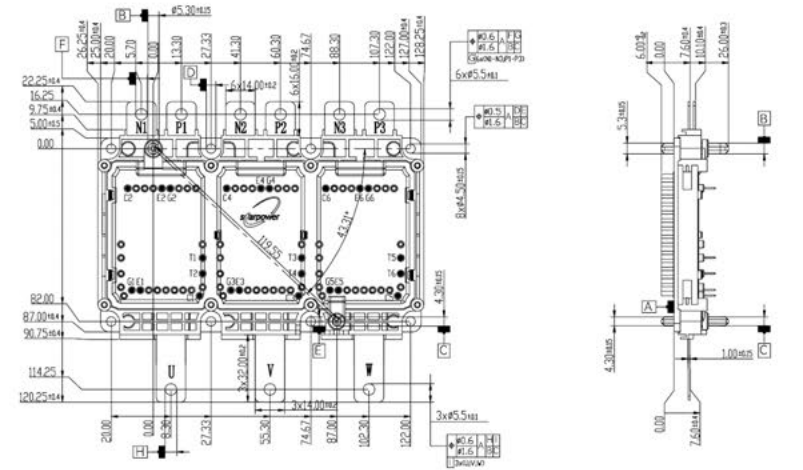

P6.2

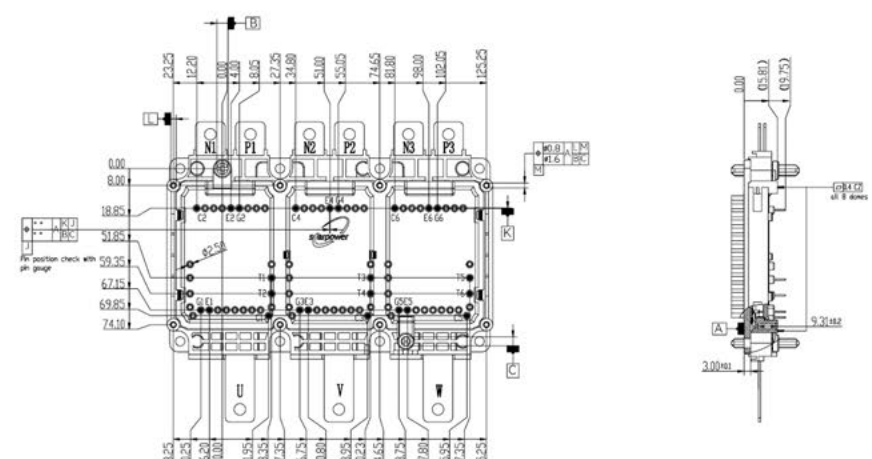
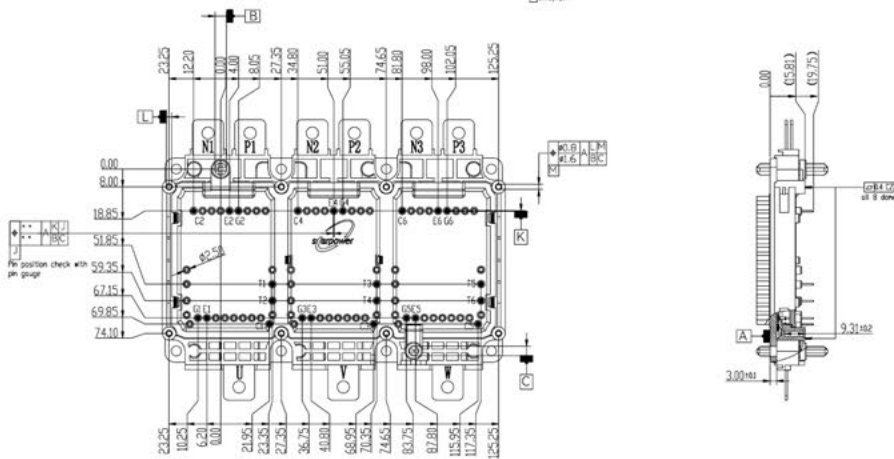

Package Outlines, mm

Automotive IGBT

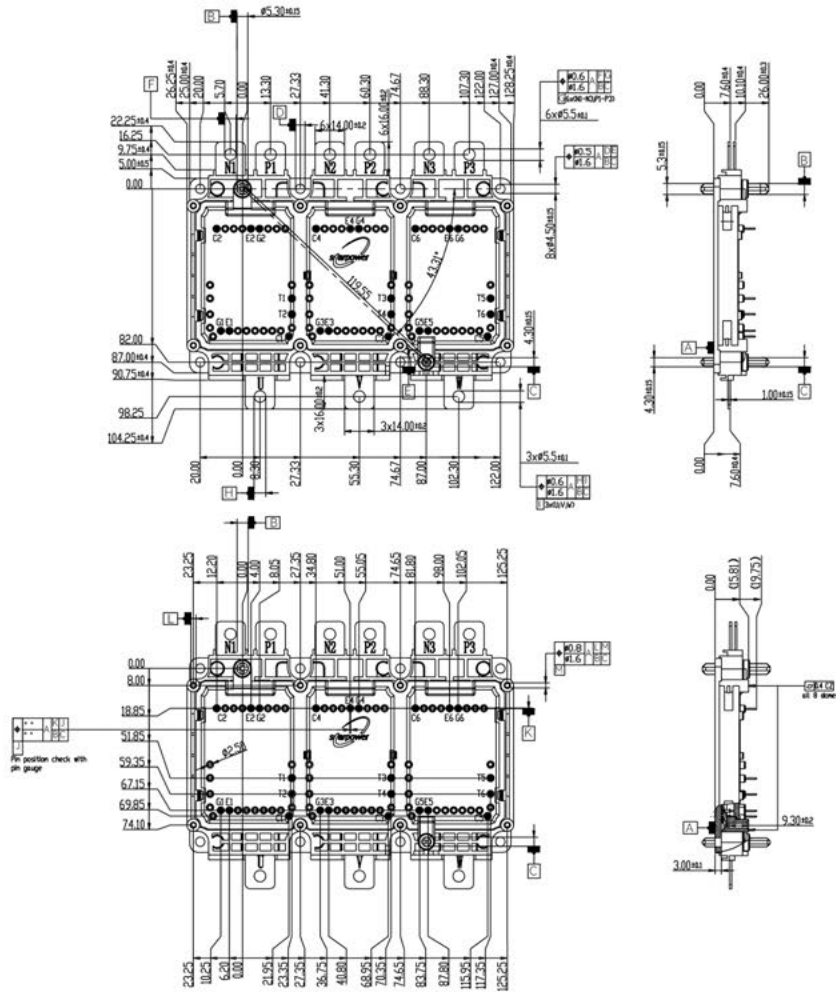

P6.4

Automotive IGBT

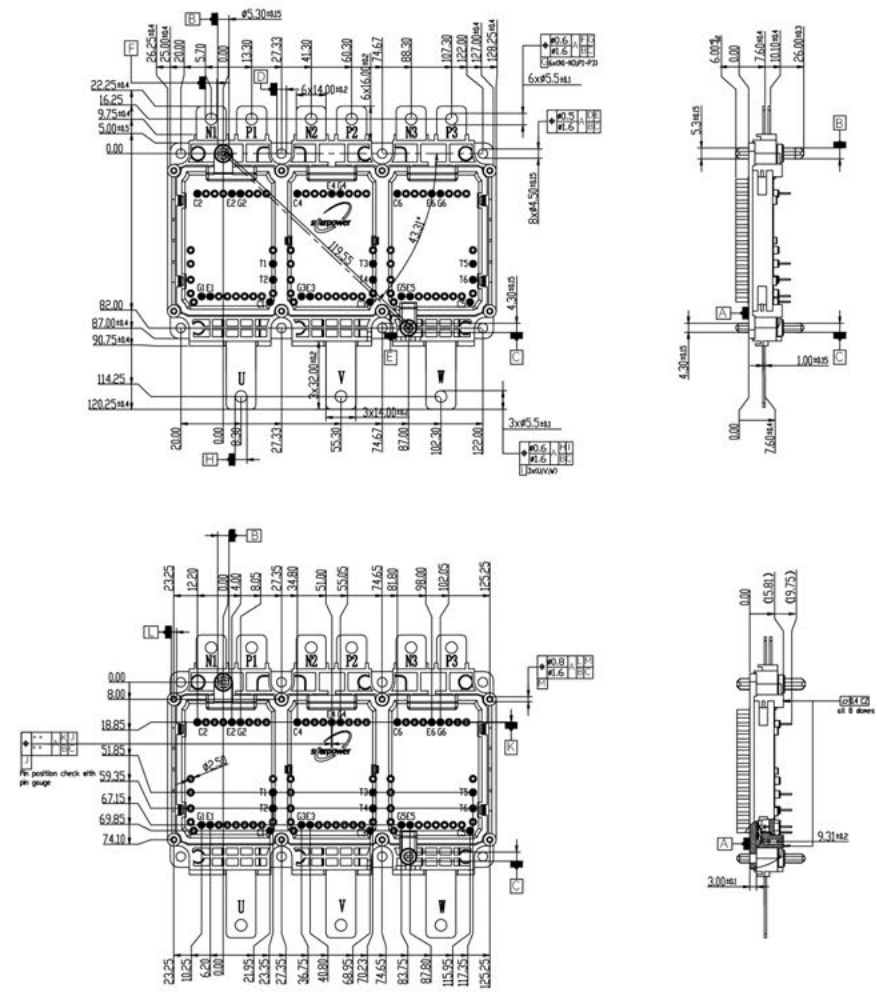

P6.3

Package Outlines, mm

Automotive IGBT

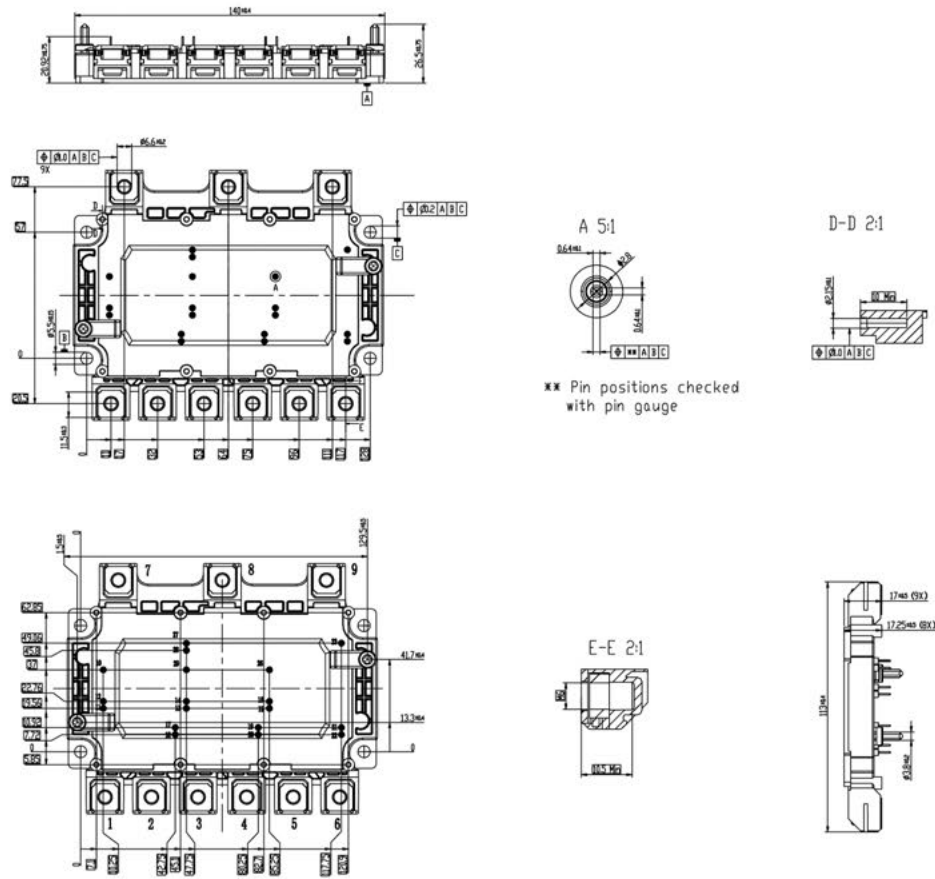

P7.2

Automotive IGBT

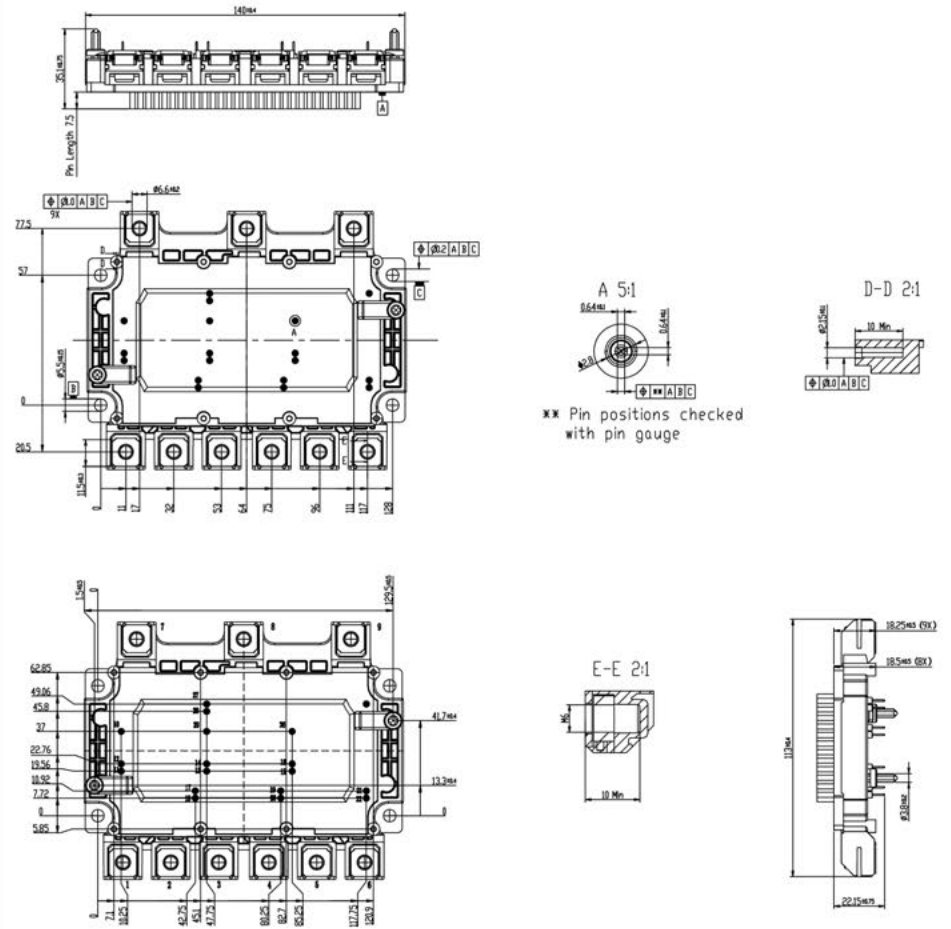

P7.1

Package Outlines, mm

Automotive IGBT

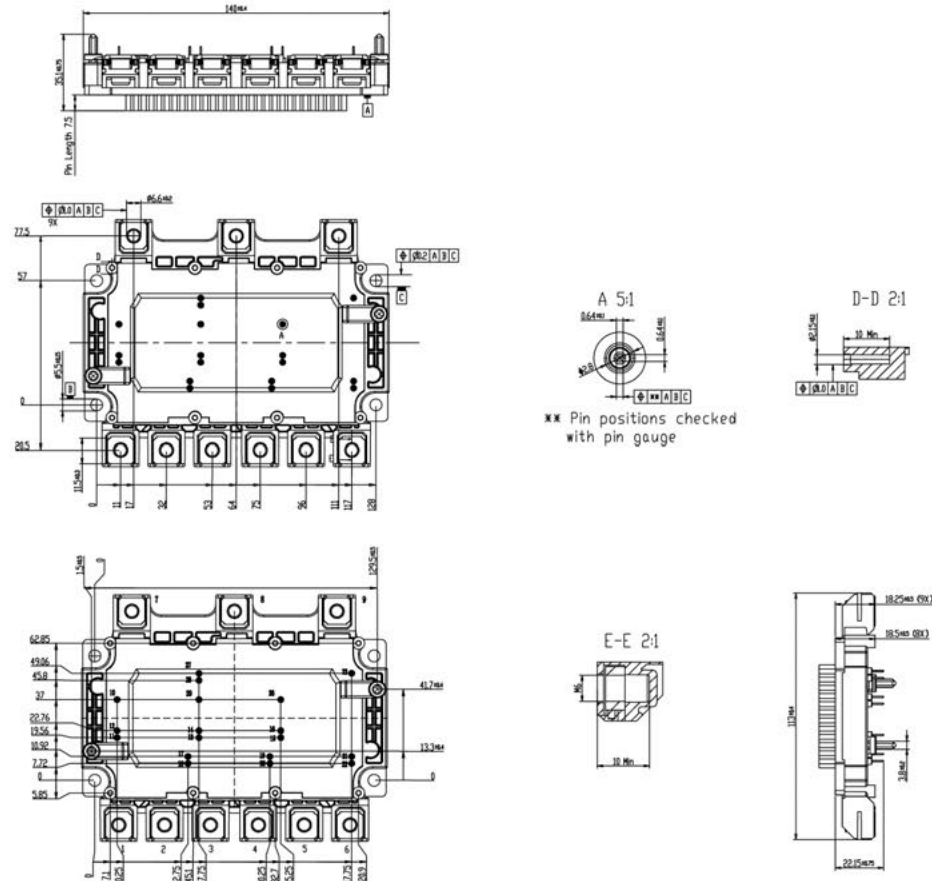

P7.0

Automotive IGBT

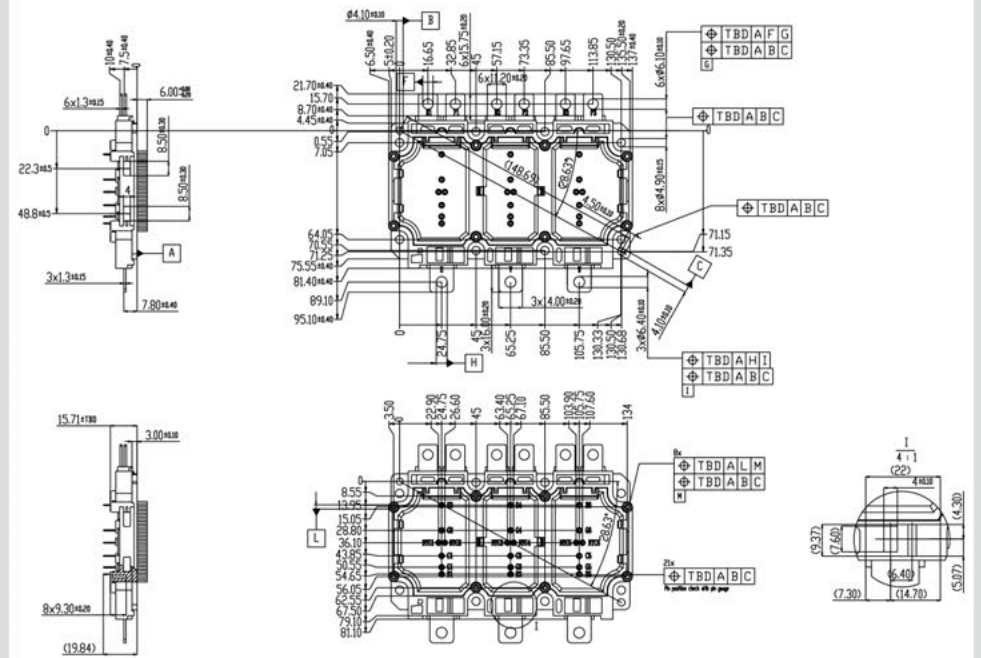

P8.0

Package Outlines, mm

PIM

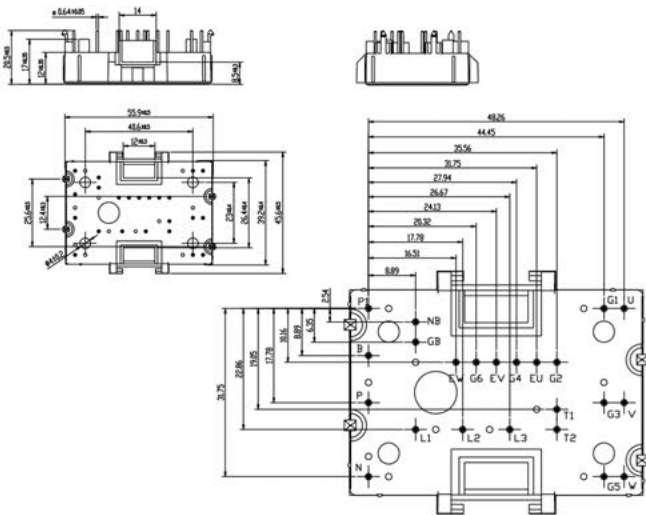

Pinpositions with tolerance ± 0.1 L1.0

PIM

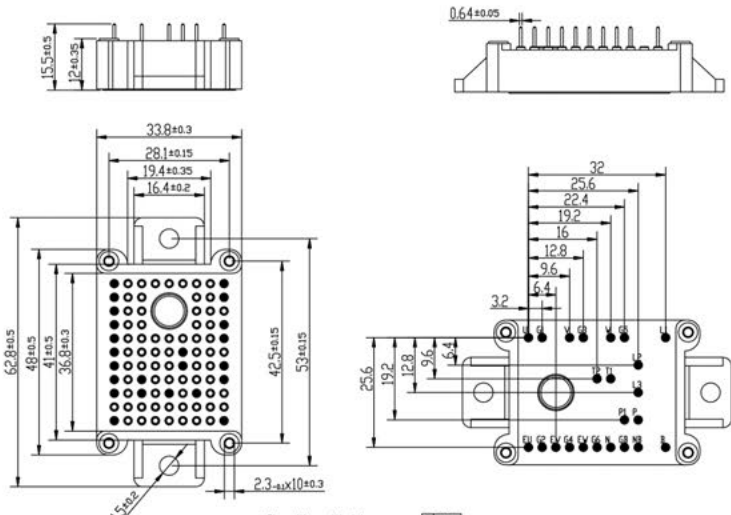

Pinpositions with tolerance ± 0.1 L2.1

PIM

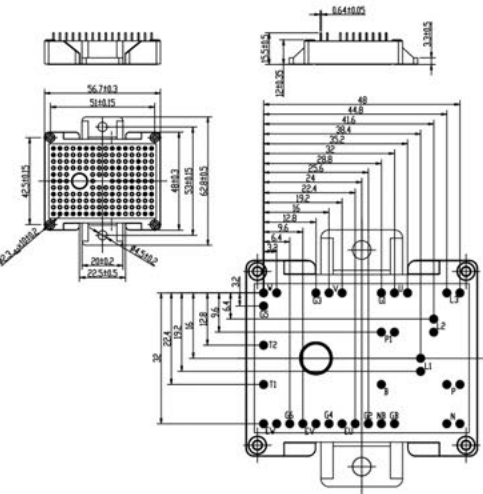

Pinpositions with tolerance ± 0.1 L3.1

PIM

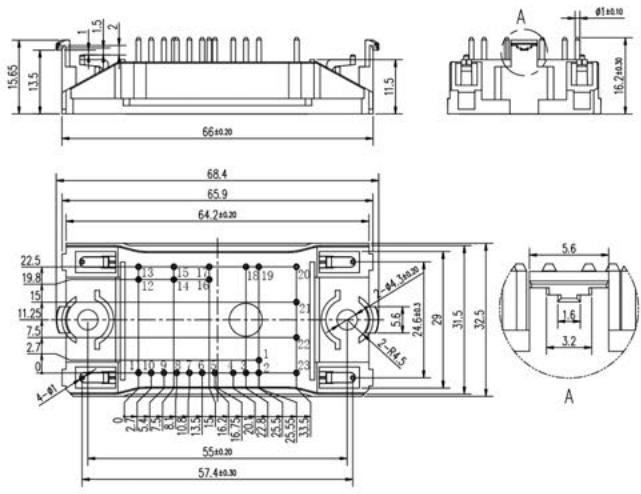

F1.0

Package Outlines, mm

PIM

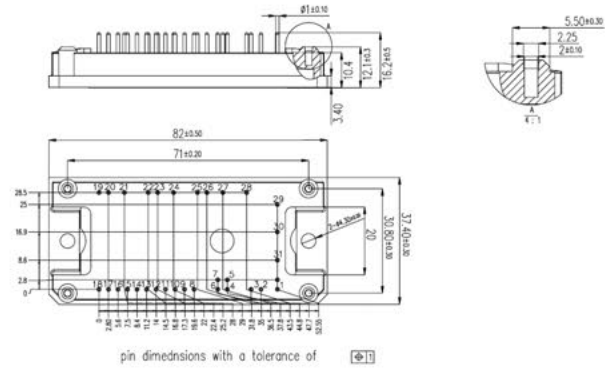

F2.0

PIM

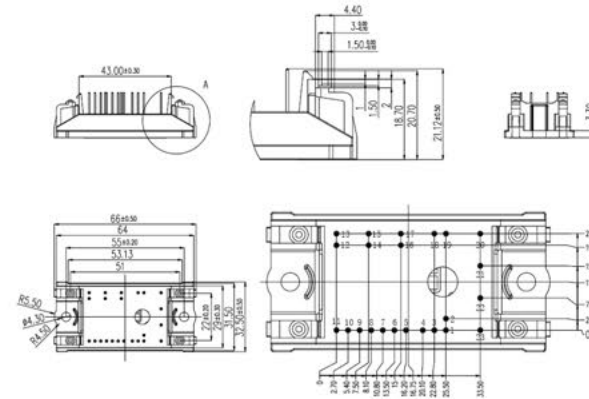

F3.0

PIM

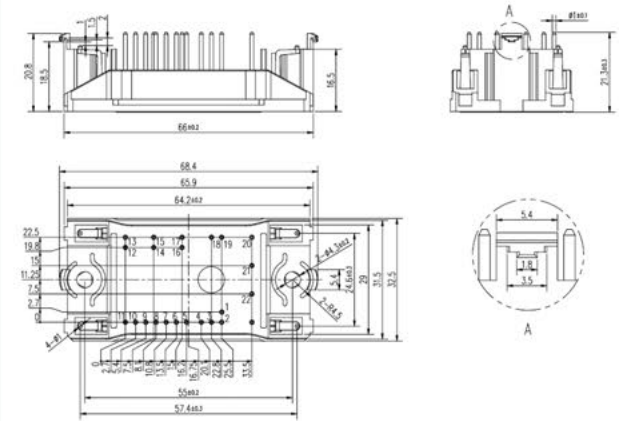

F4.0

PIM

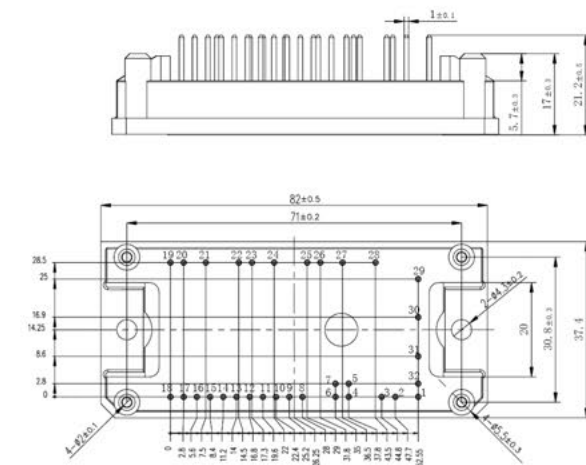

F5.0

PIM

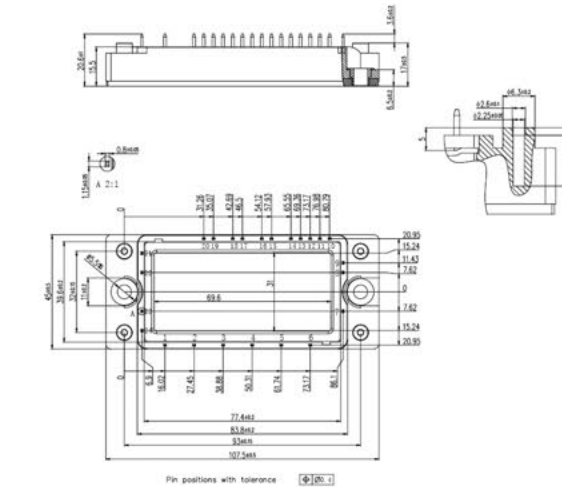

C5.0

PIM

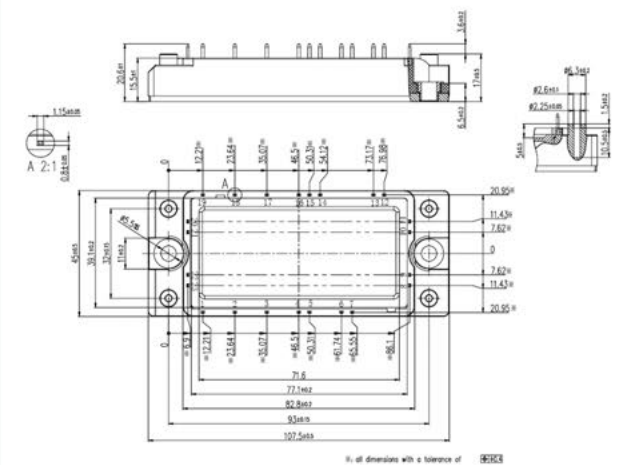

C5.3

Package Outlines, mm

PIM

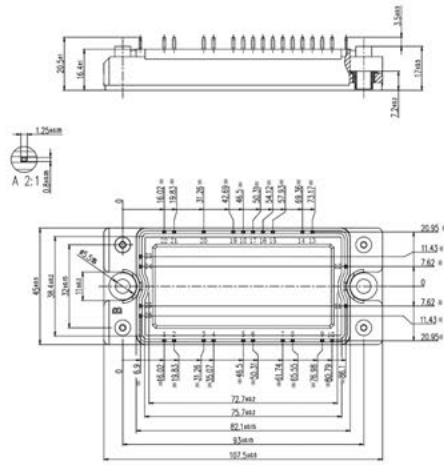

All dimensions with a tolerance of ± 0.05

C5.5

PIM

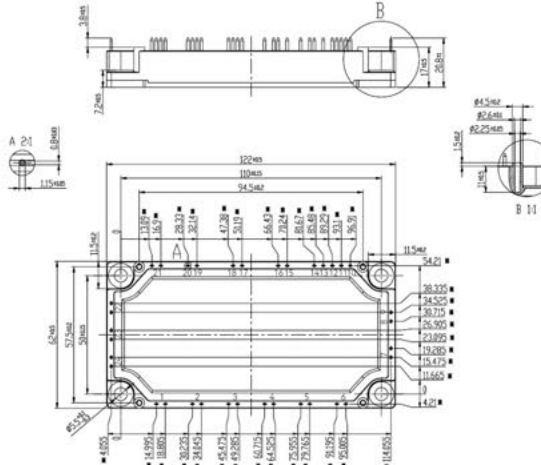

All dimensions with a tolerance of ± 0.05

C6.0

PIM

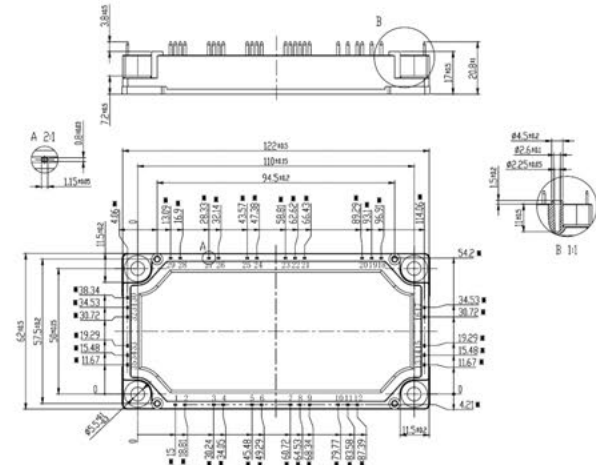

All dimensions with a tolerance of ± 0.05

C6.3

PIM

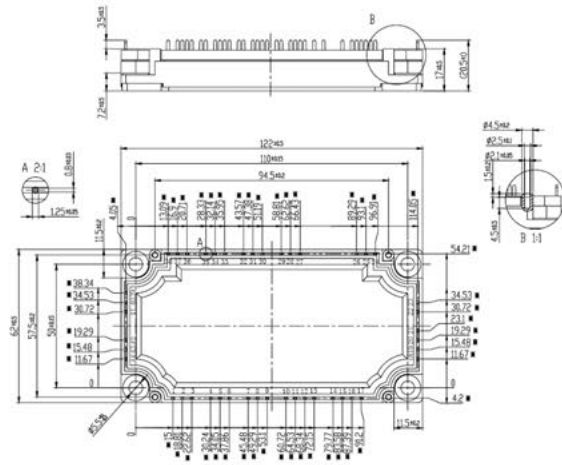

All dimensions with a tolerance of ± 0.05

C6.6

6-Pack

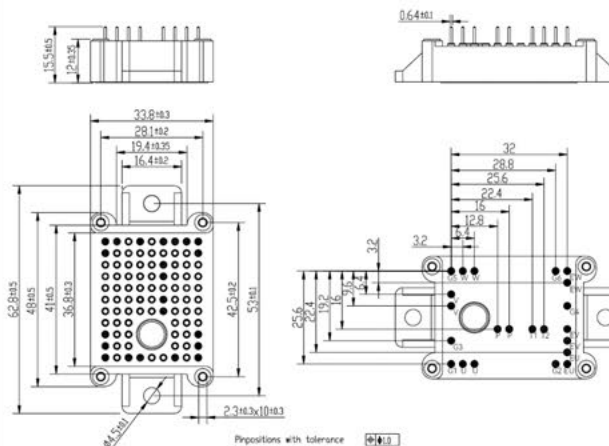

Positions with tolerance ± 0.1

L2.0

6-Pack

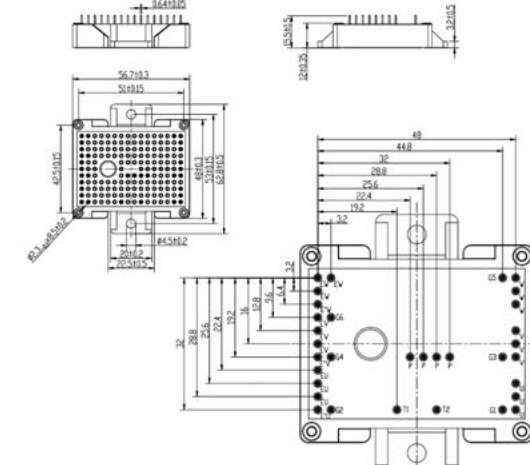

Positions with tolerance ± 0.1

L3.2

Package Outlines, mm

6-Pack

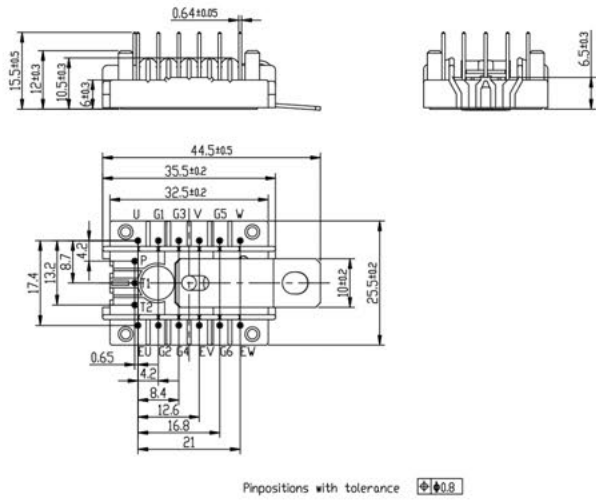

L4.0

6-Pack

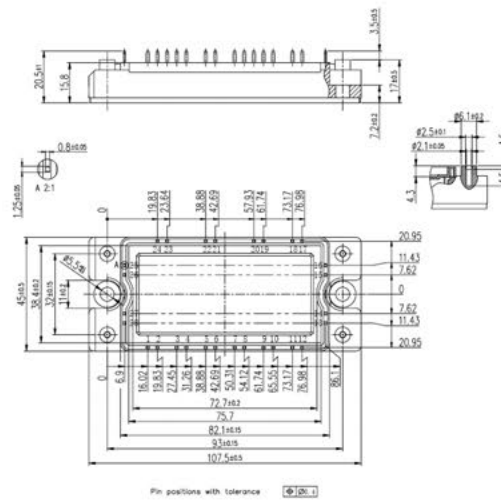

C5.2

6-Pack

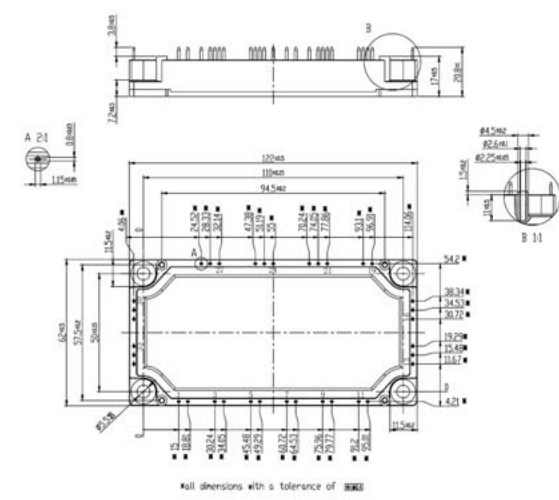

C6.2

All In One

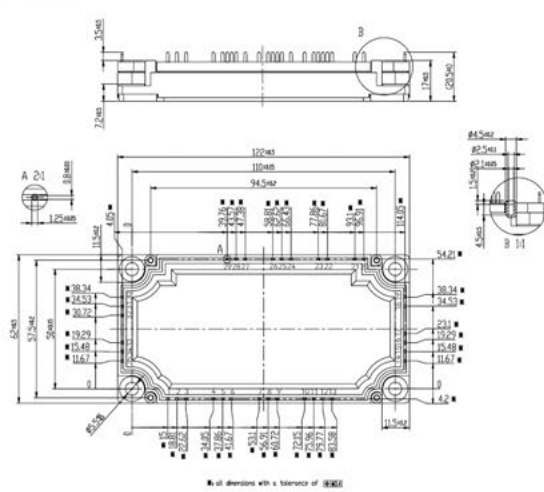

C6.12

2-Pack

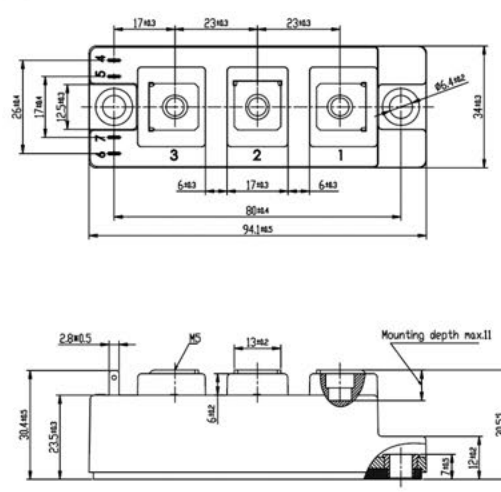

C1.0

2-Pack

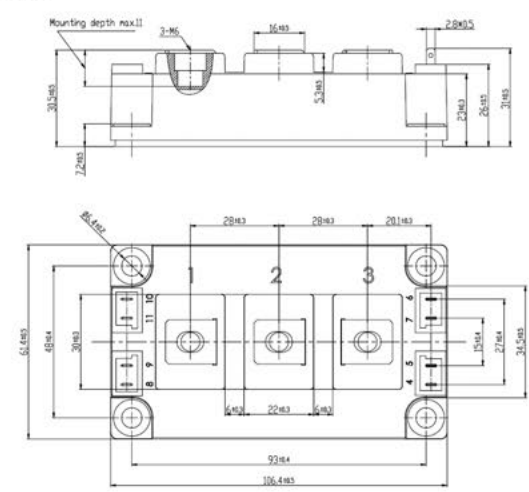

C2.0

Package Outlines, mm

2-Pack

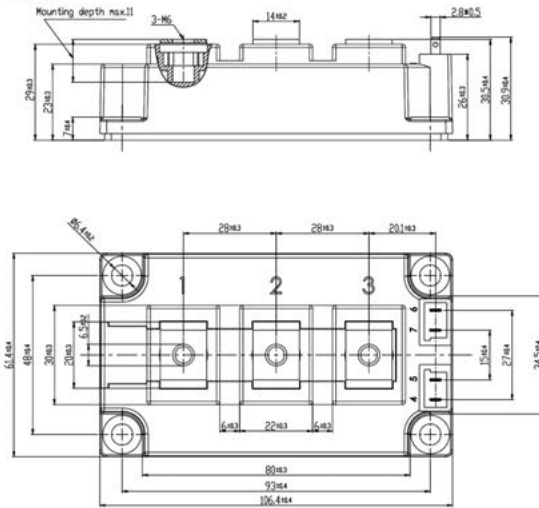

C2.5

2-Pack

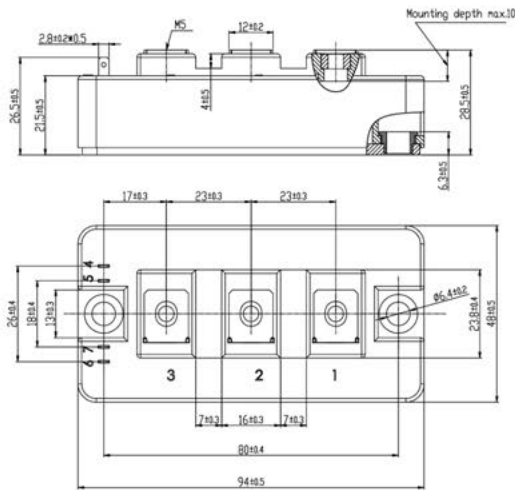

C8.0

2-Pack

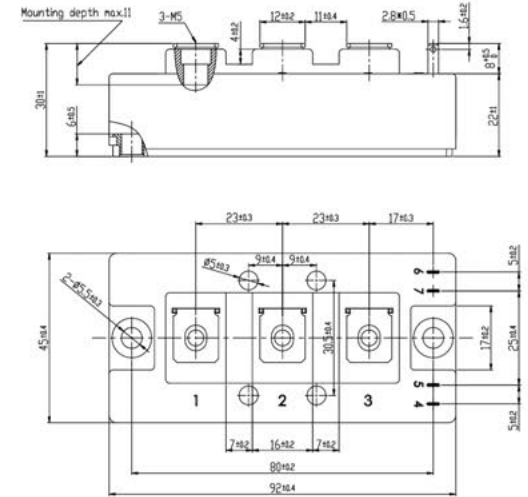

C8.1

2-Pack

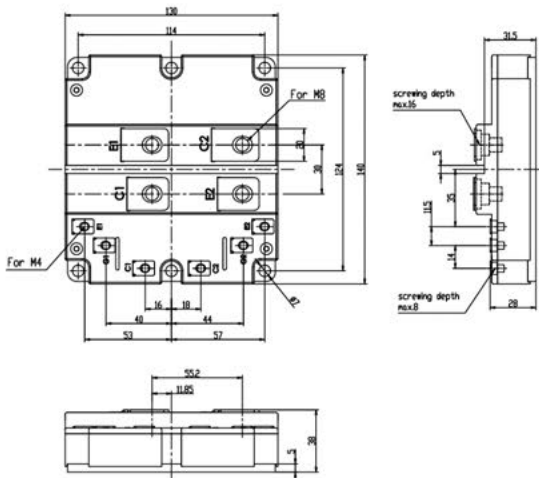

C3.1

2-Pack

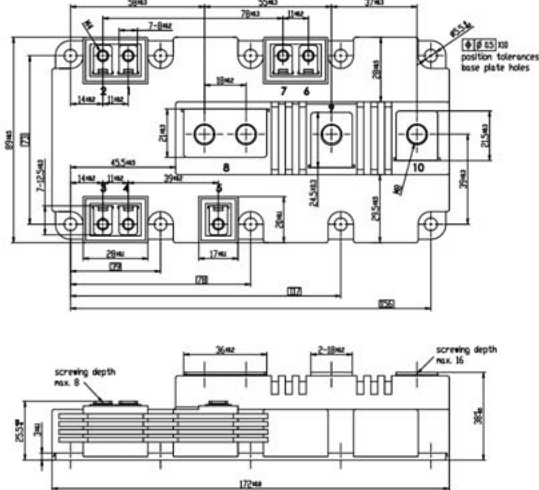

P1.0

2-Pack

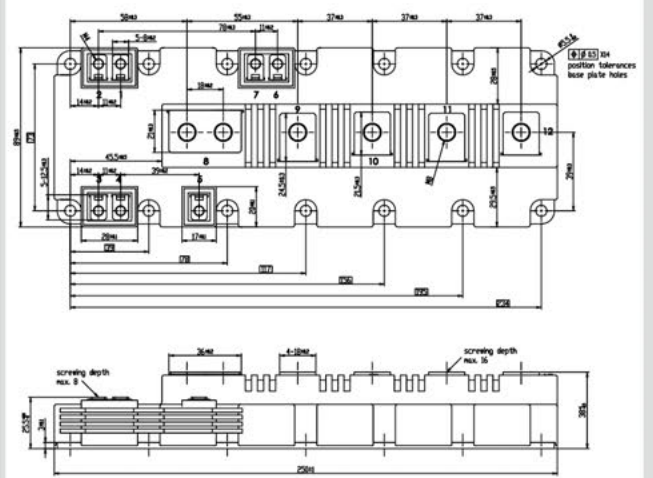

P2.0

Package Outlines, mm

2-Pack

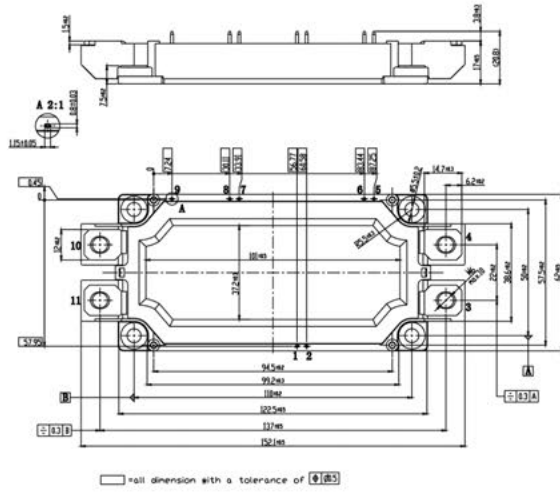

C6.1

2-Pack

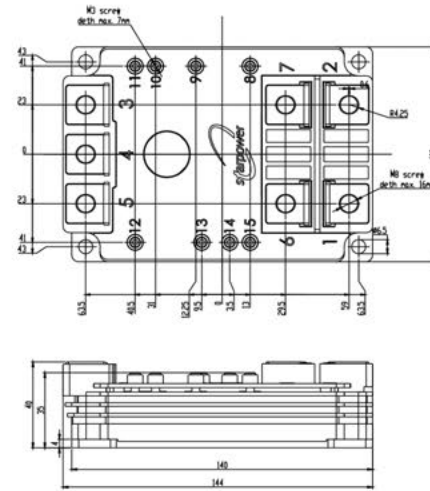

V6.0

1-Pack

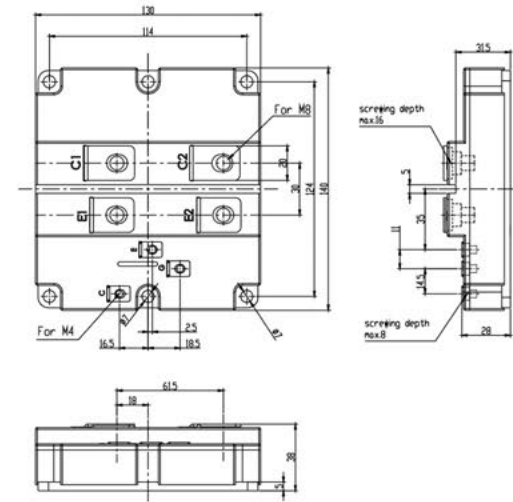

C3.0

1-Pack

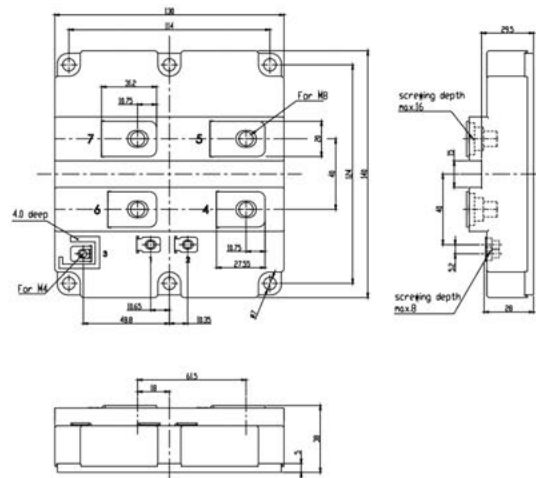

C3.2

1-Pack

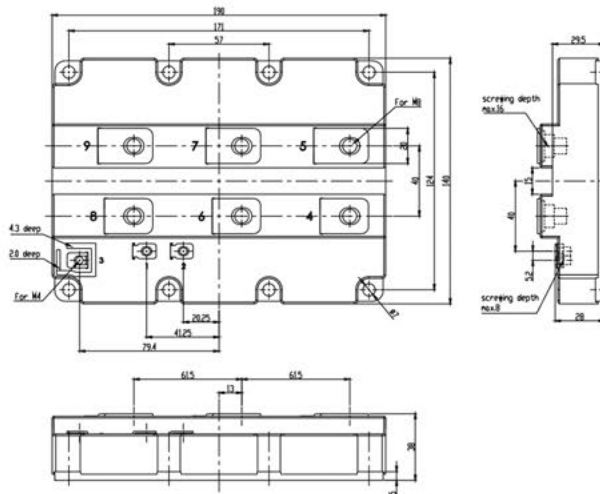

C4.0

1-Pack

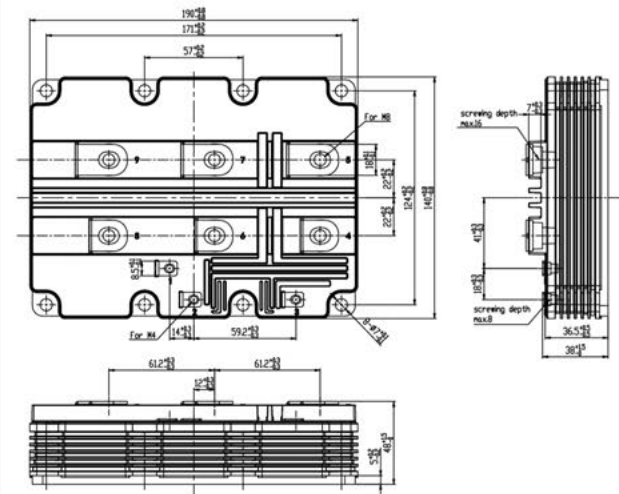

V4.0

Package Outlines, mm

3-Level

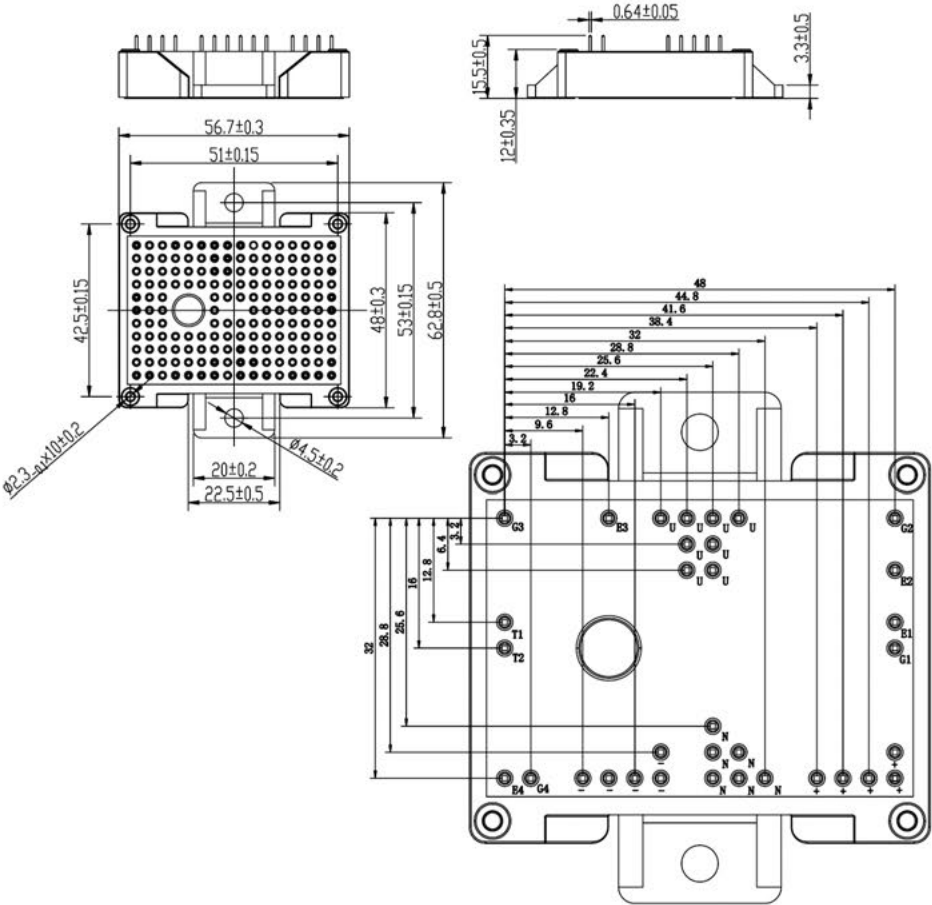

L3.3

3-Level

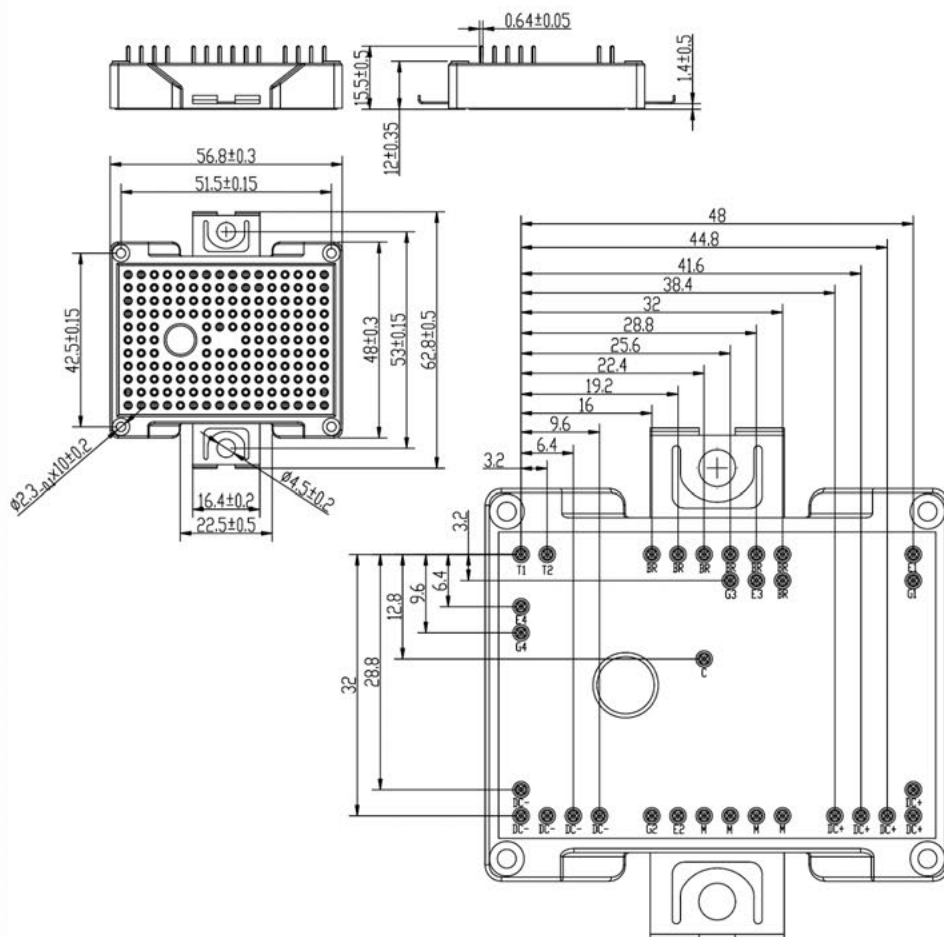

L3.4

Package Outlines, mm

3-Level

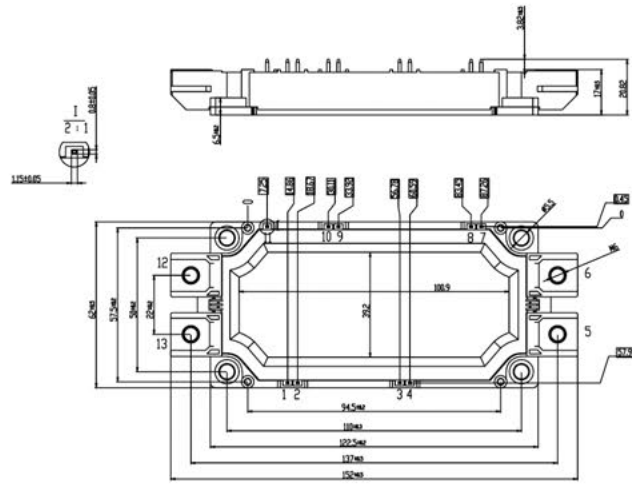

C6.15

Discrete Device

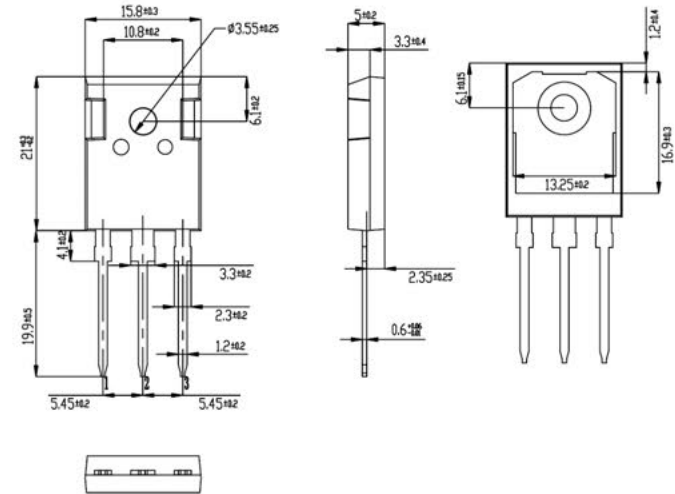

TO-247-3L

Discrete Device

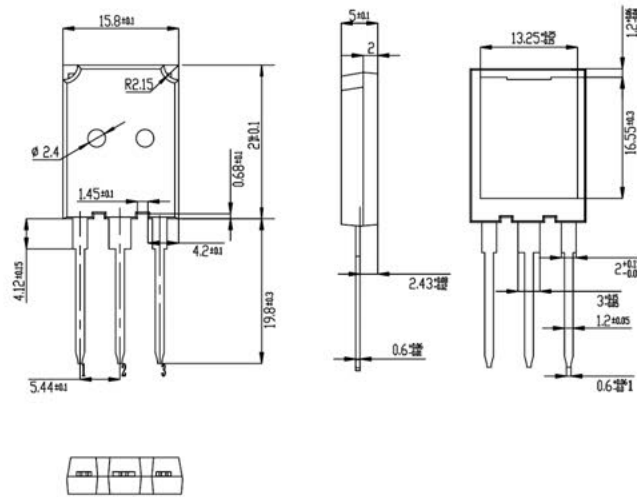

TO-247PLUS-3L

Discrete Device

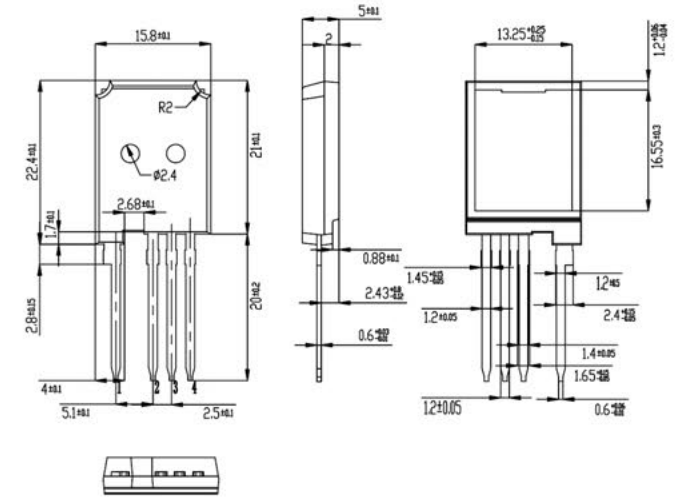

TO-247PLUS-4L

Package Outlines, mm

IPM

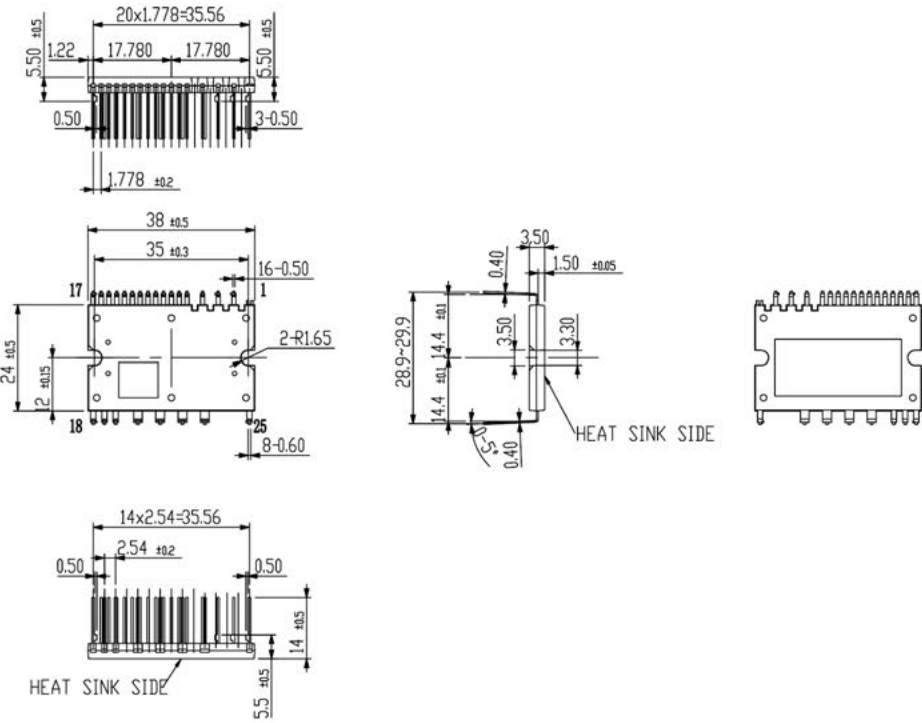

U1.0

IPM

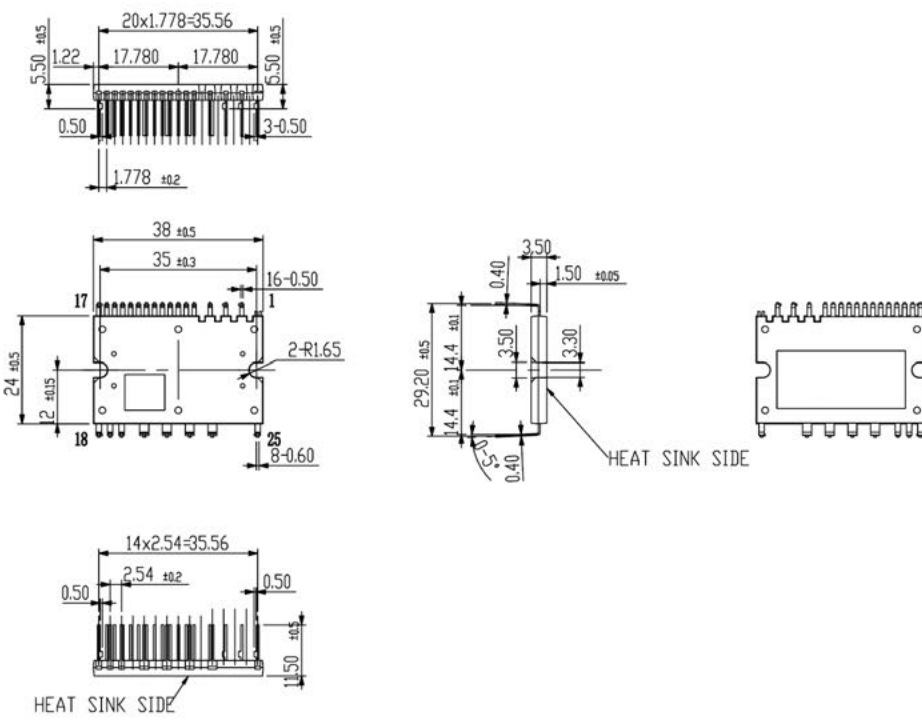

U1.1

Package Outlines, mm

IPM

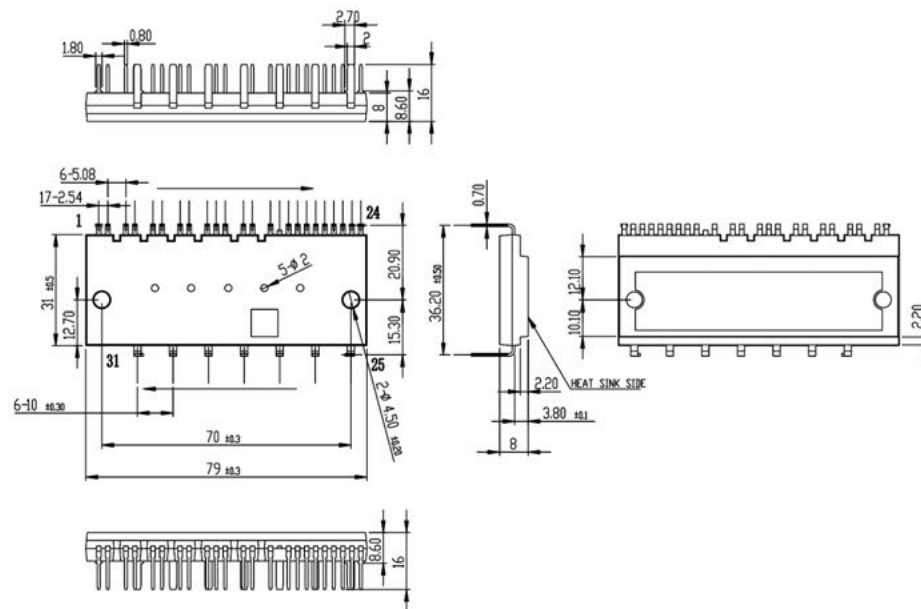

U2.0

IPM

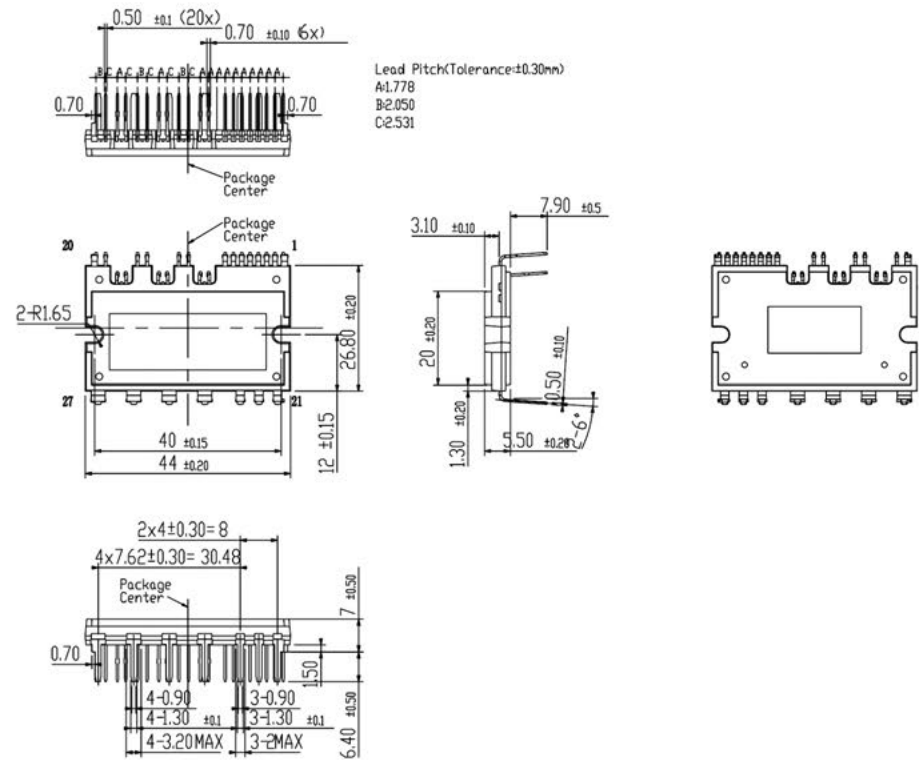

U3.0

Package Outlines, mm

IPM

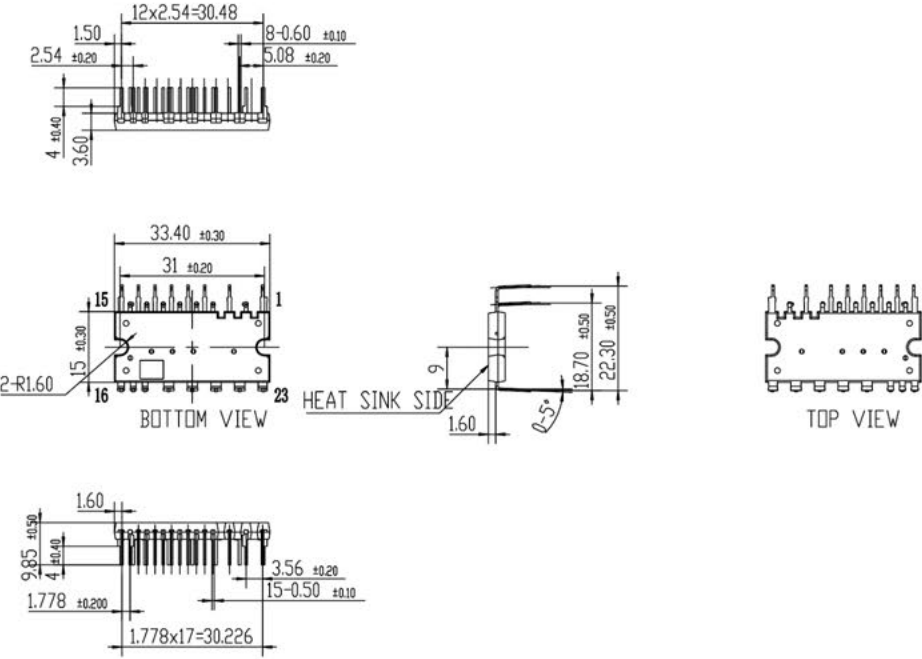

U4.0

IPM

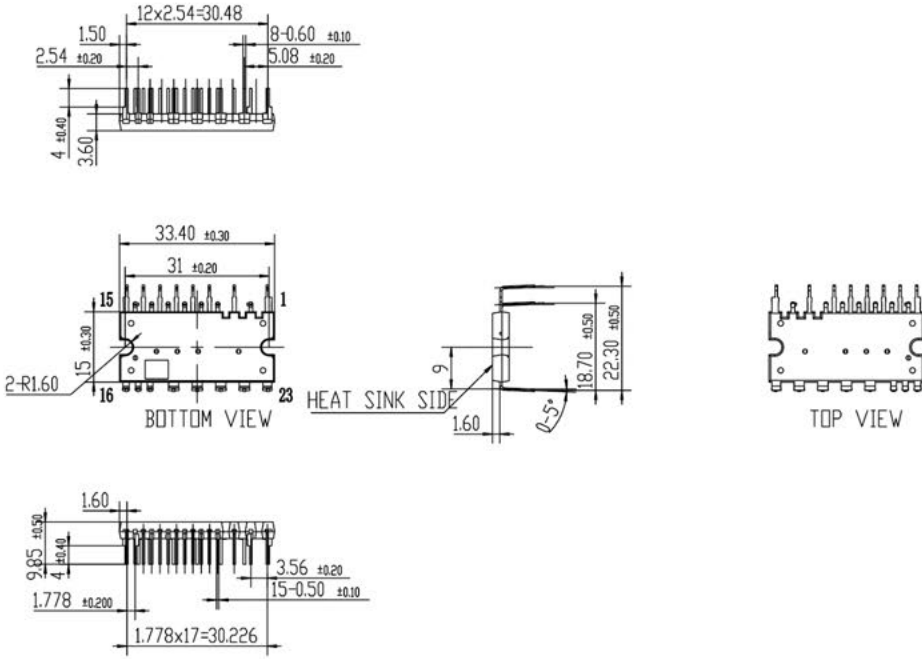

U5.0



YOUR TRUSTED POWER MODULE SUPPLIER

STARPOWER SEMICONDUCTOR LTD.

988 Kexing Road, Jiaxing, China 314006

www.powersemi.com

Tel: +86 573 82585600

Fax: +86 573 82585601



Beijing Office

Tel: + 86 137 5839 0150

Shenzhen Office

Tel: + 86 137 5839 5670

Nanjing Office

Tel: + 86 137 5839 6522

Chengdu Office

Tel: + 86 137 5839 2507

Jinan Office

Tel: + 86 137 5839 0206

Qingdao Office

Tel: + 86 137 5839 7116

Wuhan Office

Tel: + 86 137 5839 1063

Shanghai Office

Tel: + 86 135 6732 2197

StarPower Europe AG

Ai Cièss, CH - 6593 Cadenazzo, Switzerland

www.starpowereurope.com

Tel: +41 91 8504141

Fax: +41 91 8401909