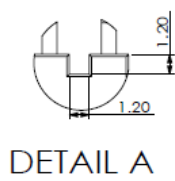
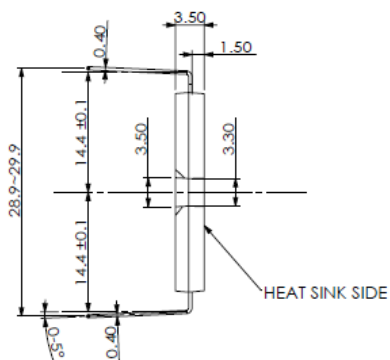
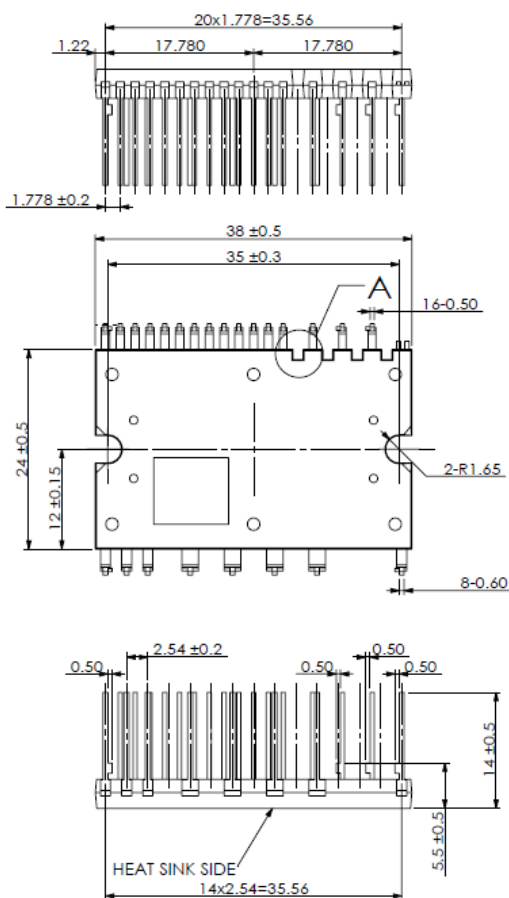


Compact - IPM ID10FFX60U1S

Features

- UL 1557 Certified.
- Adopt the latest trench IGBT technology to get a good overall loss trade-off.
- Open Emitter on N terminal for low cost current sensing application.
- Match propagation delay and arm shooting through prevention.
- Built-in bootstrap diodes with current limiting resistor.
- Provide a fault signal (FO pin) and shut-off internal IGBT when suffer S.C. and under-voltage faulty event.
- RoHS compatible.



TERMINAL CODE

1 NC	16 COM
2 V _{B(U)}	17 V _{OT}
3 V _{B(V)}	18 N _w
4 V _{B(W)}	19 N _v
5 I _{N(UH)}	20 N _U
6 I _{N(VH)}	21 W
7 I _{N(WH)}	22 V
8 V _{CC}	23 U
9 COM	24 P
10 I _{N(UL)}	25 NC
11 I _{N(VL)}	
12 I _{N(WL)}	
13 V _{CC}	
14 V _{FO}	
15 C _{SC}	

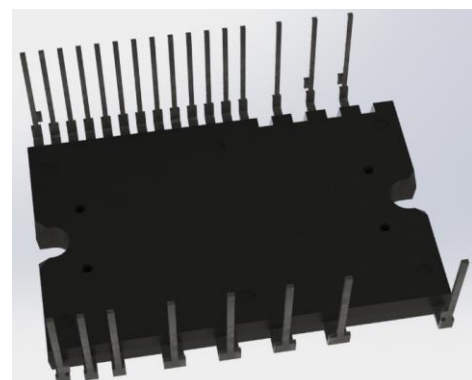
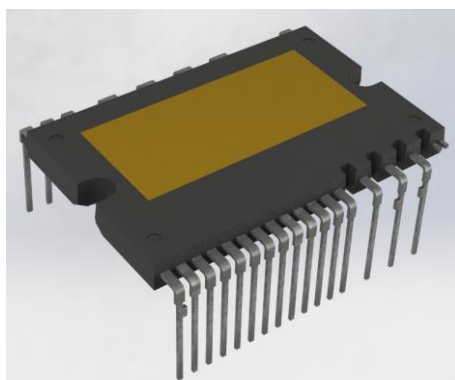


Table1: Pin Descriptions

No.	Symbol	Pin Description
1	NC	No Connection
2	$V_{B(U)}$	High - side Bias Voltage for U Phase IGBT Driving
3	$V_{B(V)}$	High - side Bias Voltage for V Phase IGBT Driving
4	$V_{B(W)}$	High - side Bias Voltage for W Phase IGBT Driving
5	$IN_{(UH)}$	Signal Input Terminal for High-side U Phase
6	$IN_{(VH)}$	Signal Input Terminal for High-side V Phase
7	$IN_{(WH)}$	Signal Input Terminal for High-side W Phase
8	V_{CC}	Supply Voltage Terminal for Driver IC
9	COM	Reference Voltage Terminal for Driver IC
10	$IN_{(UL)}$	Signal Input Terminal for Low-side U Phase
11	$IN_{(VL)}$	Signal Input Terminal for Low-side V Phase
12	$IN_{(WL)}$	Signal Input Terminal for Low-side W Phase
13	V_{CC}	Supply Voltage Terminal for Driver IC
14	V_{FO}	Fault Output Terminal
15	Csc	Short-Current Detection Input
16	COM	Reference Voltage Terminal for Driver IC
17	V_{OT}	Temperature output
18	N_W	Negative DC-Link Input Terminal for W Phase
19	N_V	Negative DC-Link Input Terminal for V Phase
20	N_U	Negative DC-Link Input Terminal for U Phase
21	W	Output Terminal for W Phase
22	V	Output Terminal for V Phase
23	U	Output Terminal for U Phase
24	P	Positive DC – Link Input
25	NC	No Connection

(see figure 2, next page)

Pin Configuration

Bottom View

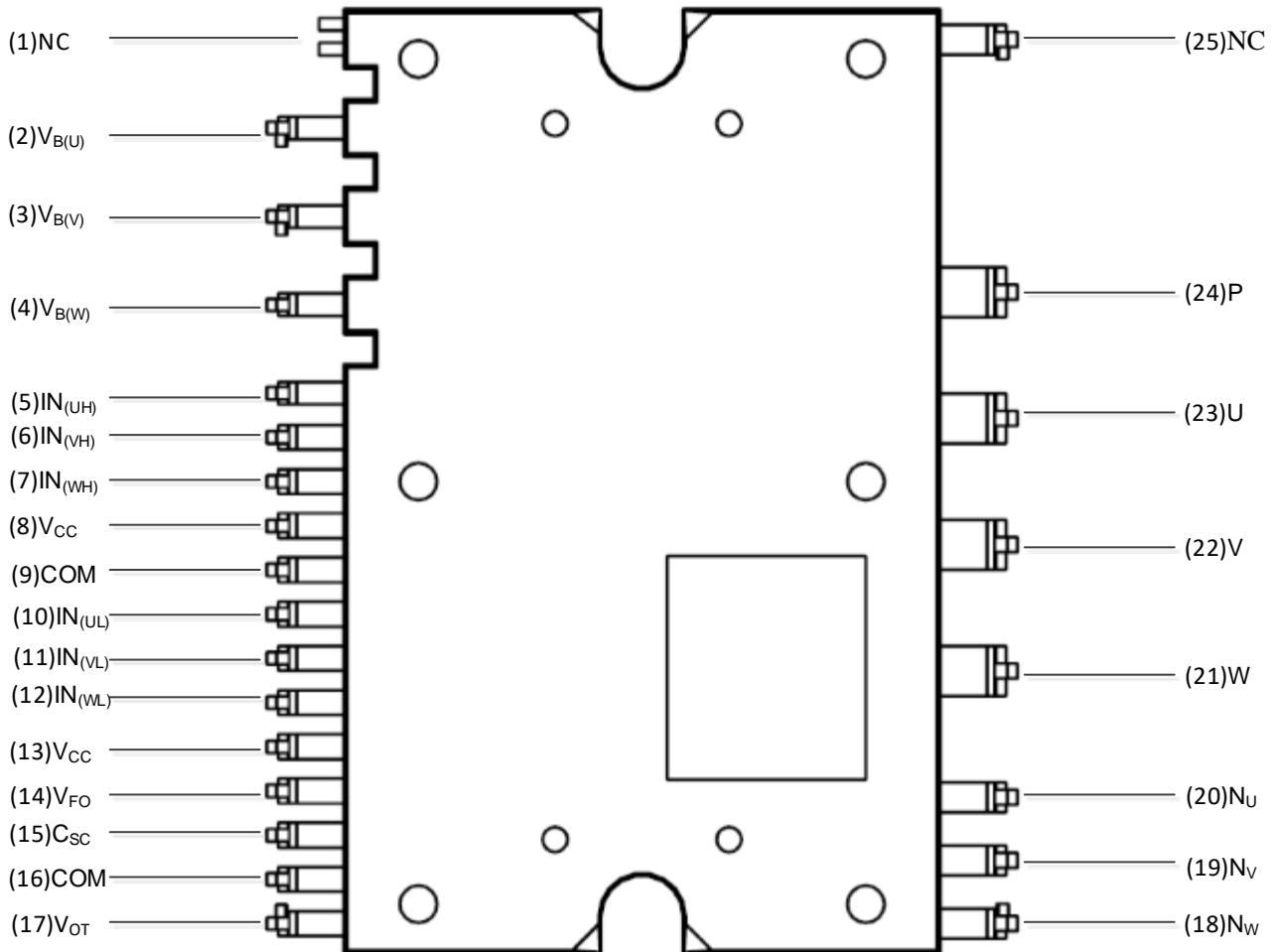


Figure 2. Pin Configuration

The IPM Internal Block Diagram

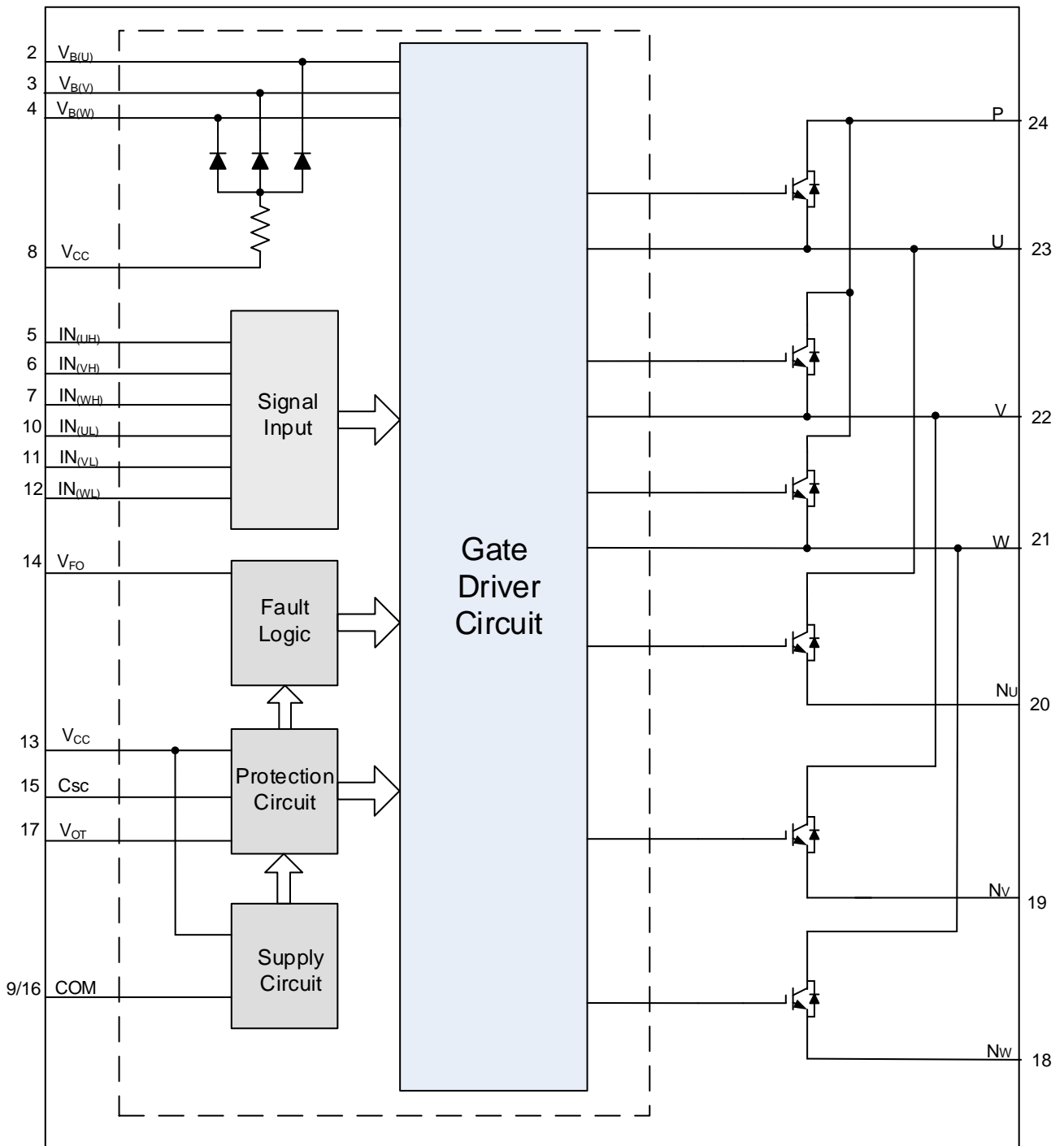


Figure 3. IPM Internal Block Diagram

Application:

- Short-circuit current protection AC 100~240Vrms class 3 phase output for low power motor control.
- Household electric appliances such as air conditioners, washing machines, refrigerators, etc...
- Low power industrial servo drives applications such as sewing machine, treadmill, etc...

MAXIMUM RATINGS ($T_j = 25^\circ\text{C}$)

INVERTER PART

Item	Symbol	Min.	Max.	Unit
Between collector to emitter voltage	V_{CES} (IGBT)	-	600	V
Supply voltage P-N	V_{PN}	-	450	V
Supply voltage (surge) P-N	$V_{PN(surge)}$	-	500	V
Each IGBT collector current	$\pm I_C$ ($T_C = 25^\circ\text{C}$)	-	10	A
Each IGBT collector current	$\pm I_C$ ($T_C = 90^\circ\text{C}$)	-	6	A
Each IGBT collector current (peak)	$\pm I_{CP}$ ($T_C = 25^\circ\text{C}$, $T_j < 150^\circ\text{C}$, Under 1ms Pulse Width)	-	20	A
Collector dissipation	P_C ($T_C = 25^\circ\text{C}$, per one chip)	-	40	W
Junction temperature	T_j (Note 1)	-	+150	$^\circ\text{C}$

Note 1: Power chip in IPM is qualified for 175°C operation. But overall junction temperature should be limited by $T_j \leq 125^\circ\text{C}$ (@ $T_c \leq 100^\circ\text{C}$) to fit long term reliability requirement.

CONTROL PART

Item	Symbol	Min.	Max.	Unit
Driver IC supply voltage	V_{CC}	-0.3	20	V
P - side floating supply voltage	$V_{B(u)S(u), B(V)S(V), B(W)S(W)}$	-0.3	20	V
Current sensing input voltage	V_{SC}	-0.3	$V_{CC}+0.3$	V
Logic input voltage	$IN_{(UH)}, IN_{(VH)}, IN_{(WH)}, IN_{(UL)}, IN_{(VL)}, IN_{(WL)}$	-0.3	$V_{CC}+0.3$	V
Fault output voltage	V_{FO}	-0.3	$V_{CC}+0.3$	V
Fault output current	I_{FO}	-	1	mA

TOTAL SYSTEM

Item	Symbol	Min.	Max.	Unit
Module case operating temperature	T_C	-20	+100	$^\circ\text{C}$
Storage temperature	T_{stg}	-40	+125	$^\circ\text{C}$
Isolation voltage (60Hz Sinusoidal, AC 1 minute, pins to heat-sink plate)	V_{iso}	-	1500	Vrms

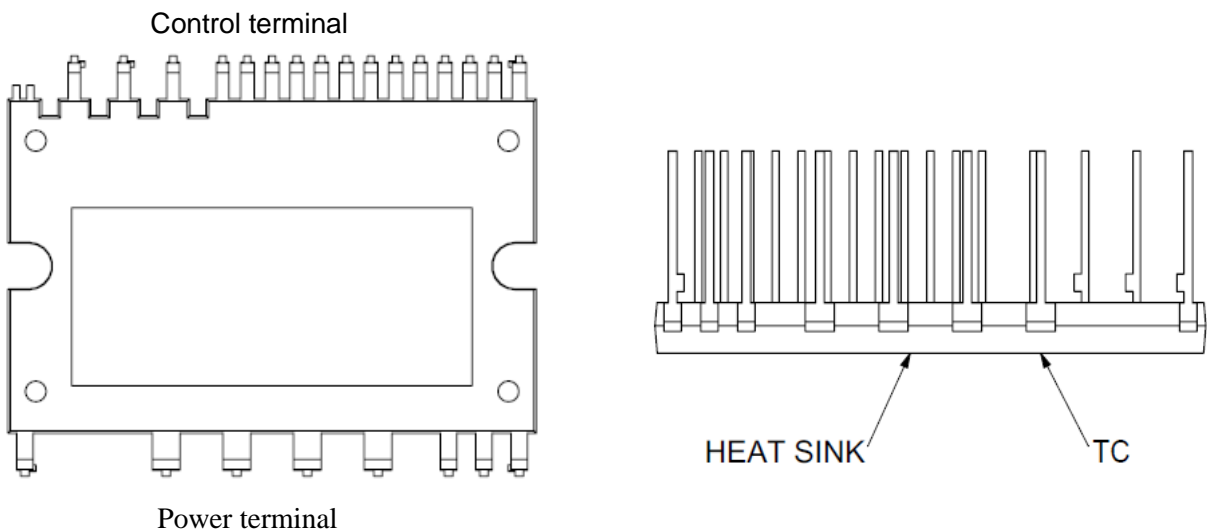


Figure 4. T_c Measurement Point

THERMAL RESISTANCE

Item	Symbol	Condition	Min.	Typ.	Max.	Unit
Junction to case thermal resistance	$R_{th(j-c)Q}$	IGBT part (1/6)	-	3.0	-	°C/W
	$R_{th(j-c)F}$	FWD part (1/6)	-	2.7	-	

ELECTRICAL CHARACTERISTICS ($T_j = 25^\circ\text{C}$)

INVERTER PART

Item	Symbol	Condition	Min.	Typ.	Max.	Unit
Collector-emitter saturation voltage	$V_{CE(sat)}$	$V_{CC} = V_{B(U)S(U)}, B(V)S(V), B(W)S(W) = 15V, I_C = 10A, V_{SC} = 0V$ $T_j = 25^\circ\text{C}$	-	1.50	-	V
FWD forward voltage drop	V_F	$T_j = 25^\circ\text{C}, -I_C = 10A$	-	1.40	-	V
Switching times (Fig. 5)	T_{on}	$V_D = 300V,$ $V_{CC} = V_{B(U)}, B(V), B(W) = 15V,$ $I_C = 10A, T_j = 25^\circ\text{C},$ $V_{IN} = 5V \leftrightarrow 0V,$ $V_{SC} = 0V, \text{ Inductive Load}$	-	0.85	-	μs
	$T_{c(on)}$		-	0.25	-	
	T_{off}		-	0.90	-	
	$T_{c(off)}$		-	0.10	-	
	T_{rr}		-	0.15	-	
Collector-emitter cut-off current	I_{CES}	$V_{CE} = V_{CES}$	-	-	500	μA

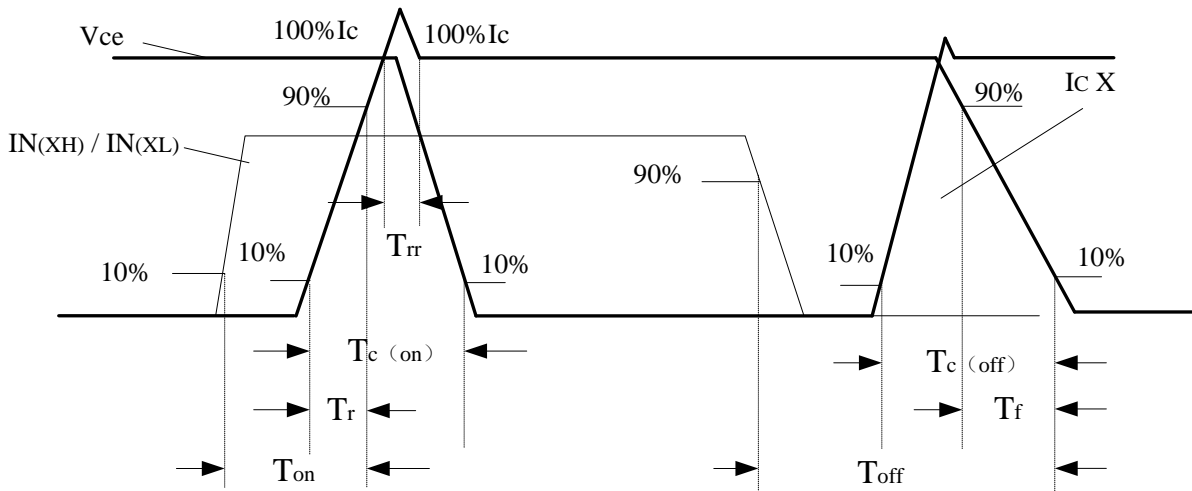


Figure 5. Switching Time Definition

CONTROL PART ($T_j = 25^\circ\text{C}$)

Item	Symbol	Condition	Min.	Typ.	Max.	Unit
$\text{IN}_{(\text{UH}, \text{VH}, \text{WH})}, \text{IN}_{(\text{UL}, \text{VL}, \text{WL})}$ ON threshold voltage	$V_{\text{th(on)}}$		-	2.0	2.4	V
$\text{IN}_{(\text{UH}, \text{VH}, \text{WH})}, \text{IN}_{(\text{UL}, \text{VL}, \text{WL})}$ OFF threshold voltage	$V_{\text{th(off)}}$		0.8	1.1	-	V
$\text{IN}_{(\text{UH}, \text{VH}, \text{WH})}$ input bias current	$I_{\text{IN}(\text{UH}, \text{VH}, \text{WH})(\text{HI})}$	$V_{\text{IN}(\text{UH}, \text{VH}, \text{WH})} = 5\text{V}$	0.7	1.0	1.5	mA
	$I_{\text{IN}(\text{UH}, \text{VH}, \text{WH})(\text{LO})}$	$V_{\text{IN}(\text{UH}, \text{VH}, \text{WH})} = 0\text{V}$	-	0	-	
$\text{IN}_{(\text{UL}, \text{VL}, \text{WL})}$ input bias current	$I_{\text{IN}(\text{UL}, \text{VL}, \text{WL})(\text{HI})}$	$V_{\text{IN}(\text{UL}, \text{VL}, \text{WL})} = 5\text{V}$	0.7	1.0	1.3	mA
	$I_{\text{IN}(\text{UL}, \text{VL}, \text{WL})(\text{LO})}$	$V_{\text{IN}(\text{UL}, \text{VL}, \text{WL})} = 0\text{V}$	-	0	-	
Driver IC supply voltage	V_{CC}		13.5	15.0	16.5	V
P - side floating supply voltage	$V_{\text{B(U)}, \text{B(V)}, \text{B(W)}}$		13.5	15.0	16.5	V
V_{CC} terminal input current	I_{C}		-	-	2.3	mA
Fault output voltage	V_{FOH}	$V_{\text{SC}} = 0\text{V}$ (Note 2)	4.9	-	-	V
	V_{FOL}	$V_{\text{SC}} = 1\text{V}$	-	-	950	mV
Short circuit trip level	$V_{\text{SC(ref)}}$	$V_{\text{CC}} = 15\text{V}, T_j = 25^\circ\text{C}$	0.455	0.480	0.505	V
Fault output pulse width	t_{FOD}		20	65	-	us
N-side supply circuit under voltage protection	UVT_{VCC}	Trip level	9.5	10.4	11.0	V
	UVR_{VCC}	Reset level	11.0	12.0	12.8	V
	UVH	Hysteresis	-	1.6	-	V
P-side supply circuit under voltage protection	UVT_{Vb}	Trip level	9.5	10.4	11.0	V
	UVR_{Vb}	Reset level	11.0	12.0	12.8	V
	UVH	Hysteresis	-	1.6	-	V
$\text{IN}_{(\text{UL}, \text{VL}, \text{WL})}$ Input filter time	$t_{\text{IN, FIL}}$	$V_{\text{IN}} = 0 \text{ \& \ } 5\text{V}$ (Note 3)	100	200	-	ns
Temperature Output	V_{OT}	LVIC temperature= 90°C	-	2.77	-	V
		LVIC temperature= 25°C	-	1.13	-	V
VF	Bootstrap diode forward voltage	$I_{\text{f}} = 10\text{mA}, T_j = 25^\circ\text{C}$	0.8	-	1.1	V
R	Limiting resistance	Individual resistor	-	25	-	Ohm

Note 2: V_{FO} output is open collector type, so this signal line should be pulled up to the +5V power supply with approximately 4.7K Ω

Note 3: For high side PWM, $\text{IN}_{(\text{UH}, \text{VH}, \text{WH})}$ pulse width must be ≥ 1 us.

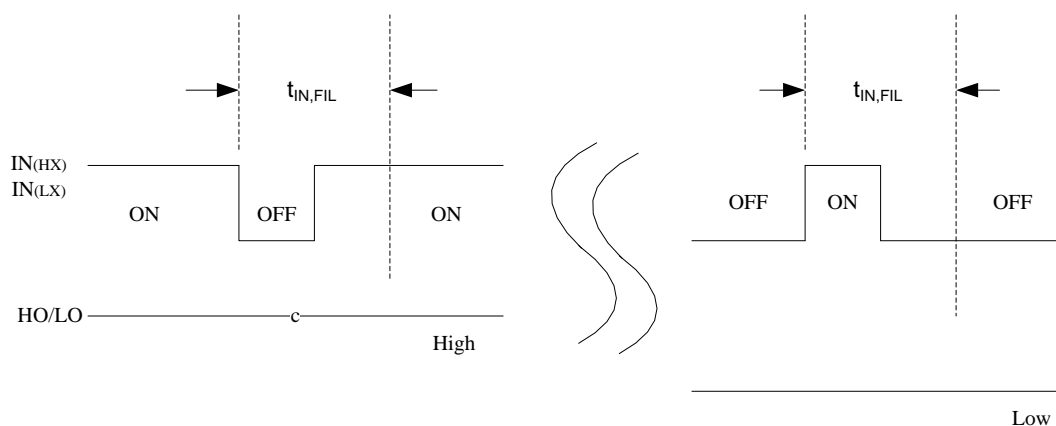
Input Filter Function

Figure 6. Input Filter Function

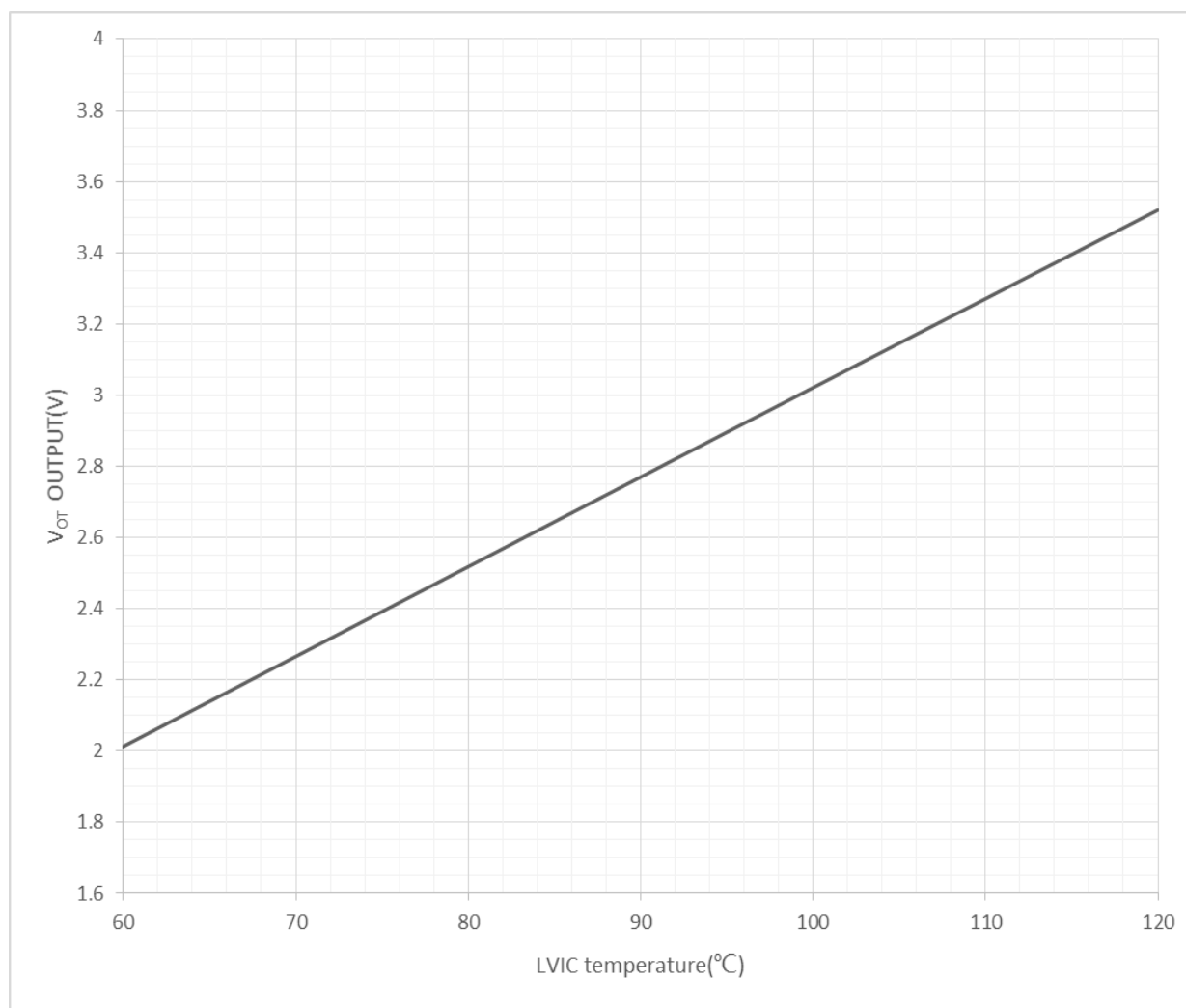


Figure 7. V_{OT} output characteristics (typical value)

RECOMMENDED OPERATION CONDITIONS

Item	Symbol	Condition	Min.	Typ.	Max.	Unit
DC – Link Supply voltage	V_D	Applied between P-N	0	400	450	V
Driver IC supply voltage	V_{CC}	Applied between V_{CC} - COM	13.5	15.0	16.5	V
P - side floating supply voltage	V_{BS}	Applied between $V_{B(u.v.w)} - V_{S(u.v.w)}$	13.5	15.0	16.5	V
Input ON threshold voltage	$V_{sc(ON)}$	Applied between $IN_{(UH.VH.WH)} - COM$ and $IN_{(UL.VL.WL)} - COM$	0 ~ 0.65			V
Input OFF threshold voltage	$V_{sc(OFF)}$		4.0 ~ 5.5			V
Supply voltage ripple	$\Delta V_D, \Delta V_{DB}$		-1	-	1	V/ μs
Arm shoot-through blocking time	t_{dead}		1	-	-	μs
PWM input frequency	f_{PWM}	$T_C \leq 100^\circ C, T_j \leq 125^\circ C$	-	15	-	kHz

MECHANICAL CHARACTERISTICS AND RATINGS

Item	Condition		Min.	Typ.	Max.	Unit
Mounting torque	Mounting screw: M3	Recommended 0.65N•m	0.60	0.65	0.70	N•m
Weight		--	-	9.5	-	g
Heat-sink flatness		--	-50	-	100	μm

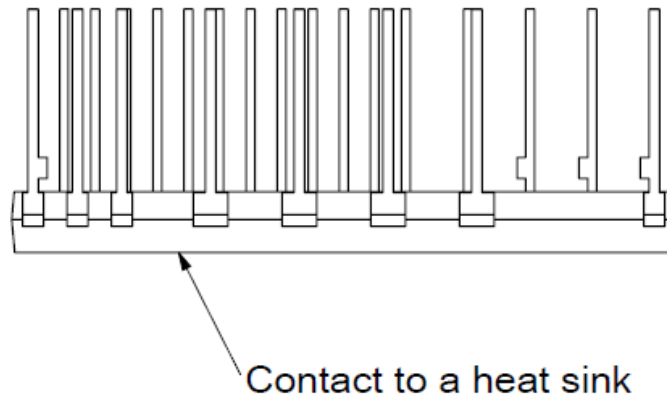


Figure 8. Measurement Location of Heat-sink Flatness

Input/Output Timing Diagram

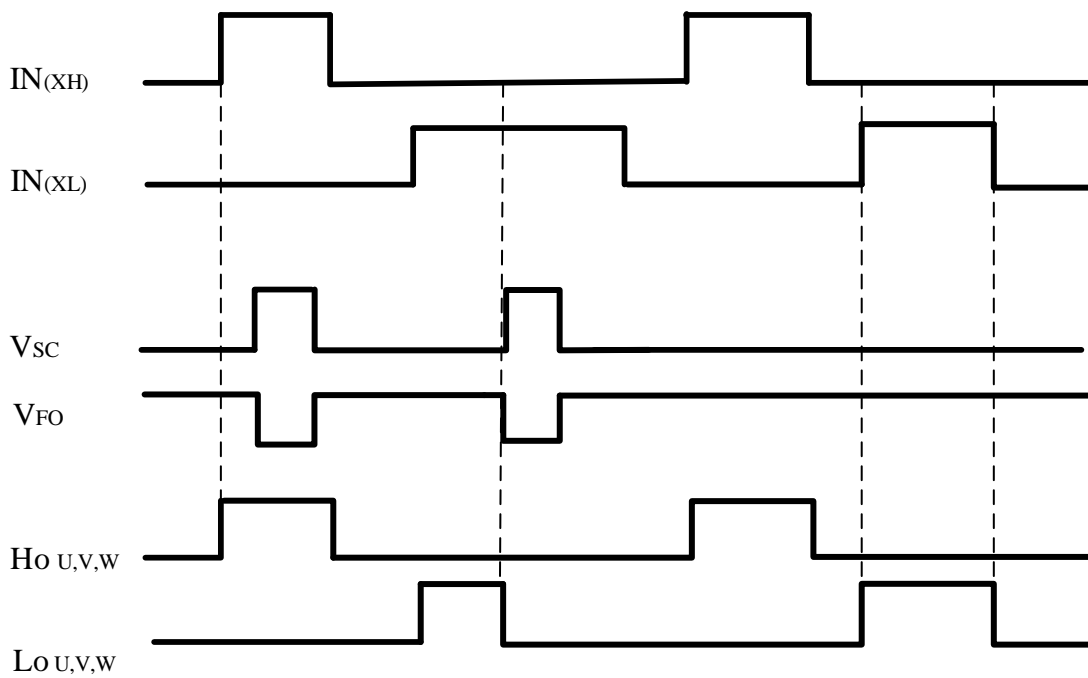


Figure 9. Input/Output Timing Diagram

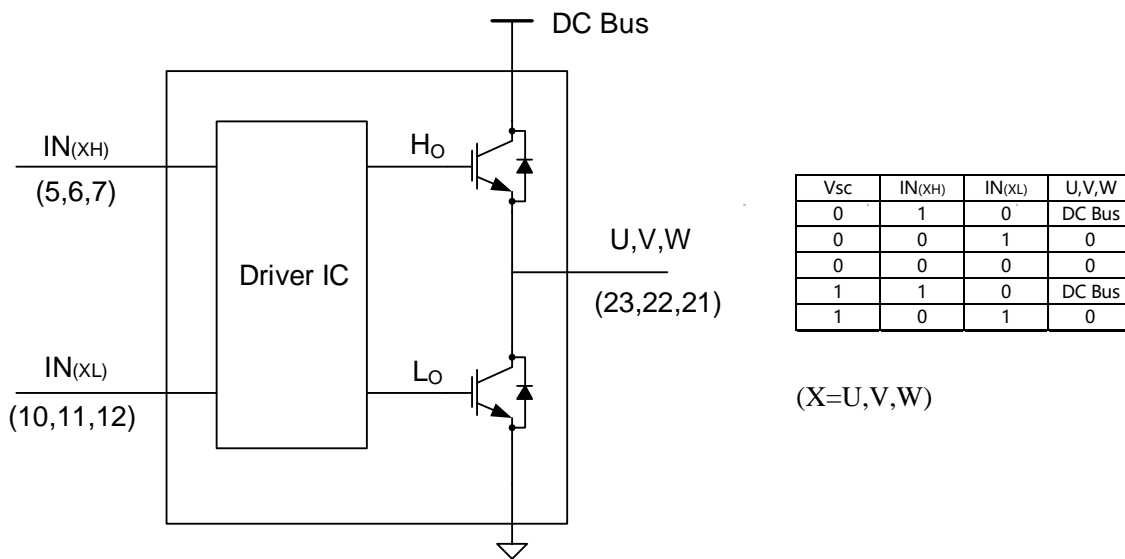


Figure 10. Input/Output Signal Circuit

IPM Short-Circuit Protection Function (N-side only with the external shunt resistor and RC filter)

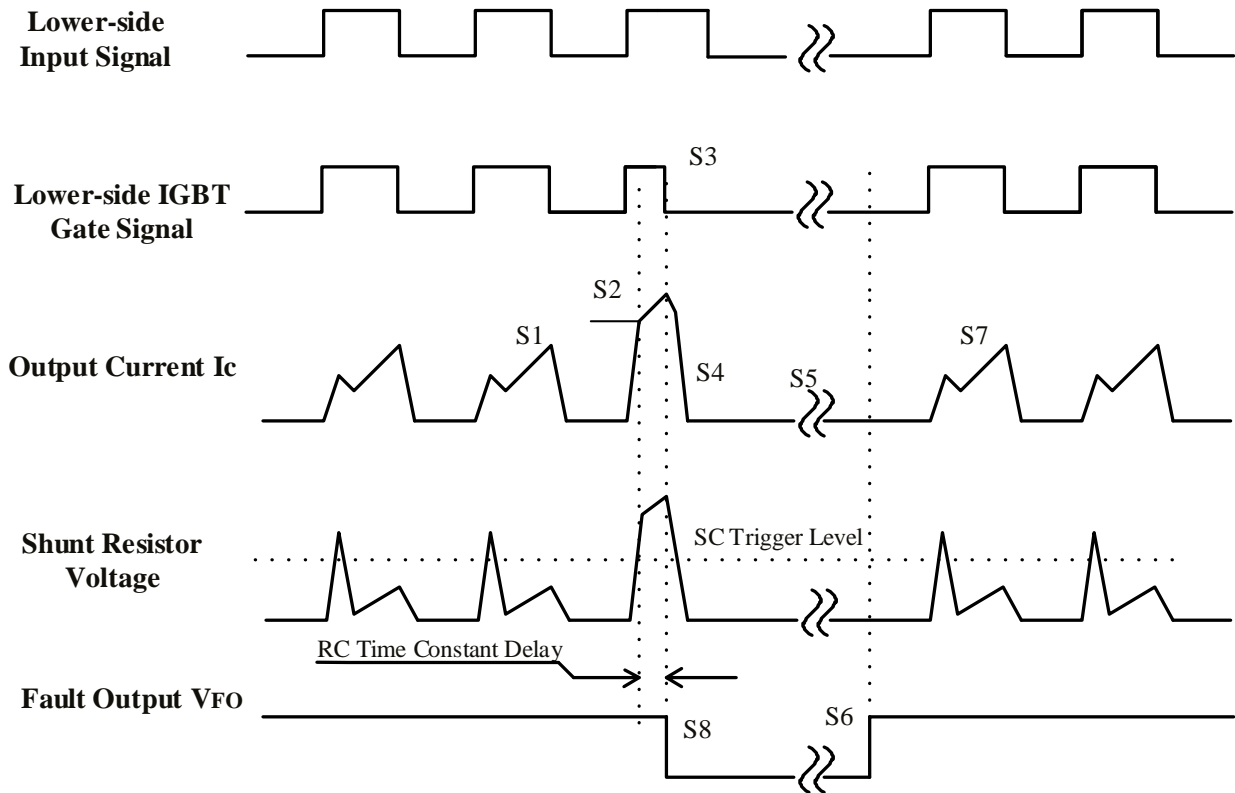


Figure 11. Timing Chart of SC Operation

- S1. The Lower-side IGBT's are controlled by input PWM signal.(Normal operation)
- S2. Short circuit event occurs and reaches the limited level. (SC protection is trigger.)
- S3. All N-side IGBT gate driving signals are disabled.
- S4. Current is cut off caused by IGBT turns OFF.
- S5. Disabled state.
- S6. Fo finishes output, but IGBT of each phase returns to normal state until inputting next ON signal(L→H).
- S7. IGBT returns for normal operation when fault state is reset.
- S8. Fault output starts once SC protection is trigger.

IPM Under-Voltage Protection Function

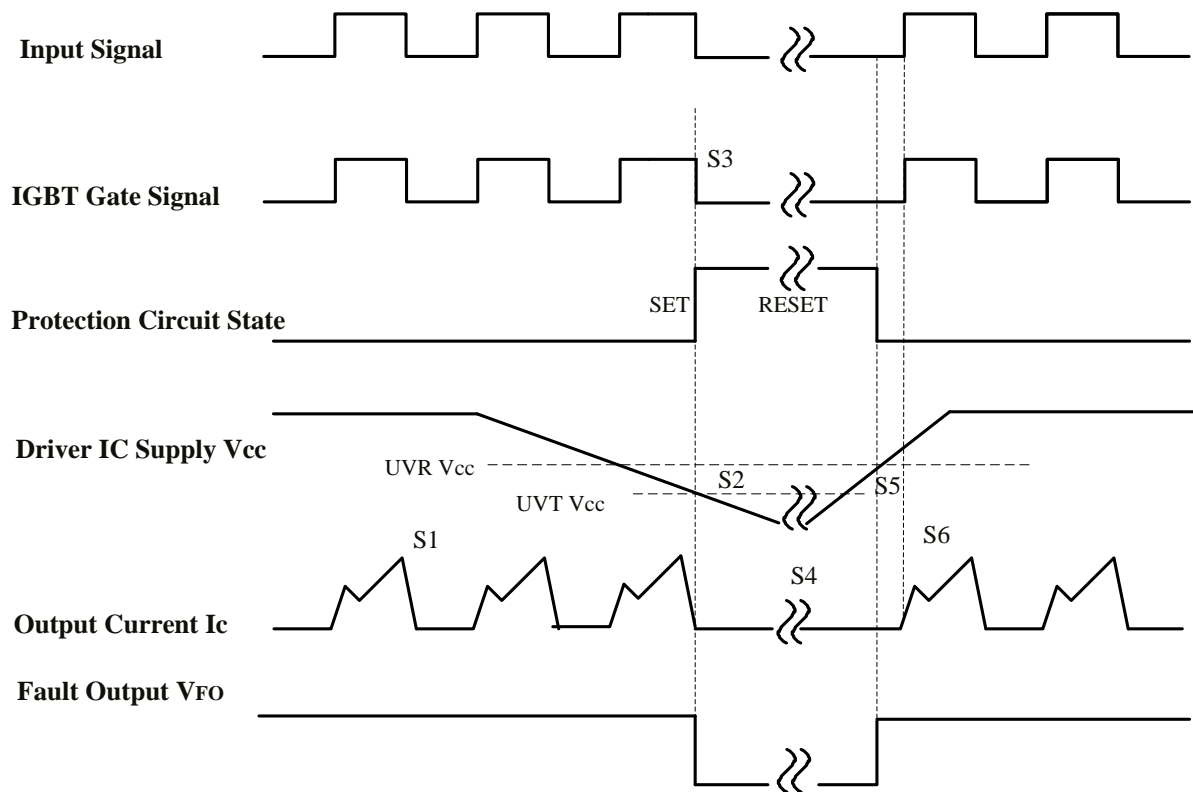


Figure 12. Timing Chart of Under-Voltage Operation

- S1. The IGBT's are controlled by input PWM signal.(Normal operation)
- S2. Under-voltage protection is trigger.
- S3. IGBT driving signals are disabled when fault condition occur.
- S4. Fault state and the period will be able to control by external capacitor value.
- S5. Under-voltage event is recovered.
- S6. IGBT returns for normal operation when fault state is reset.

Direct Input (without Photo Coupler) Interface Example

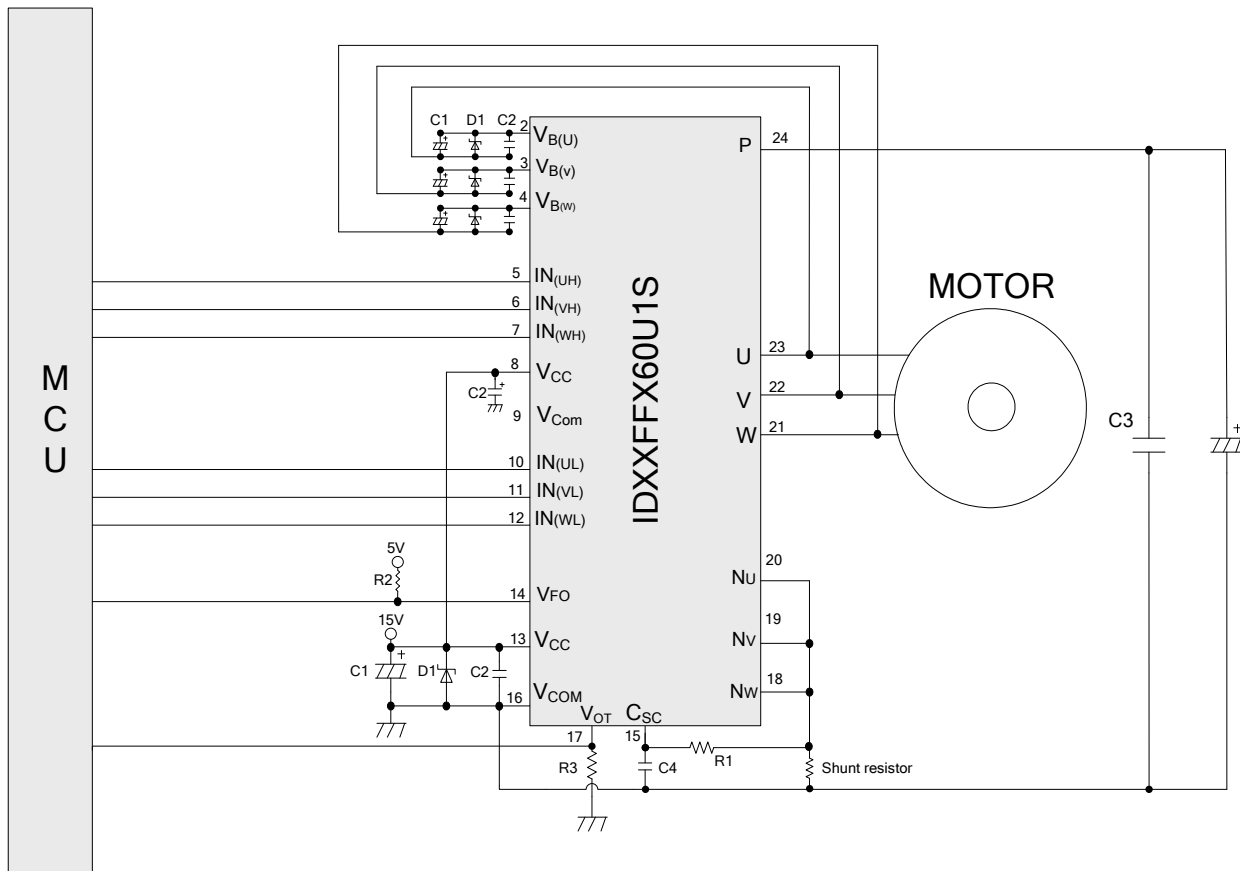


Figure 13. Typical Application Circuit Interface Example without Photo-Coupler

Design reference:

1. R1 : 100Ω
2. R2 : 4.7KΩ (VFO output is open collector so to have a pull high resistor is needed.)
3. R3 : 5k-200k pull down resistor for getting linear output characteristics at low temperature below room temperature.
4. C1 : 10 ~ 100μF (Electrolytic, low impedance)
5. C2 : 100 ~ 1000pF (Ceramic) (The capacitor could filter the noise, but should be careful to the dead time)
6. C3 : 220μF (Electrolytic, low impedance)
7. D1 : Zener diode (It is recommended to insert a Zener diode to prevent gate lifting and surge destruction)
8. Only connect either pin 9 or pin 16 to ground, do not connect both together to form the ground loop internally.

Current Sense Scheme

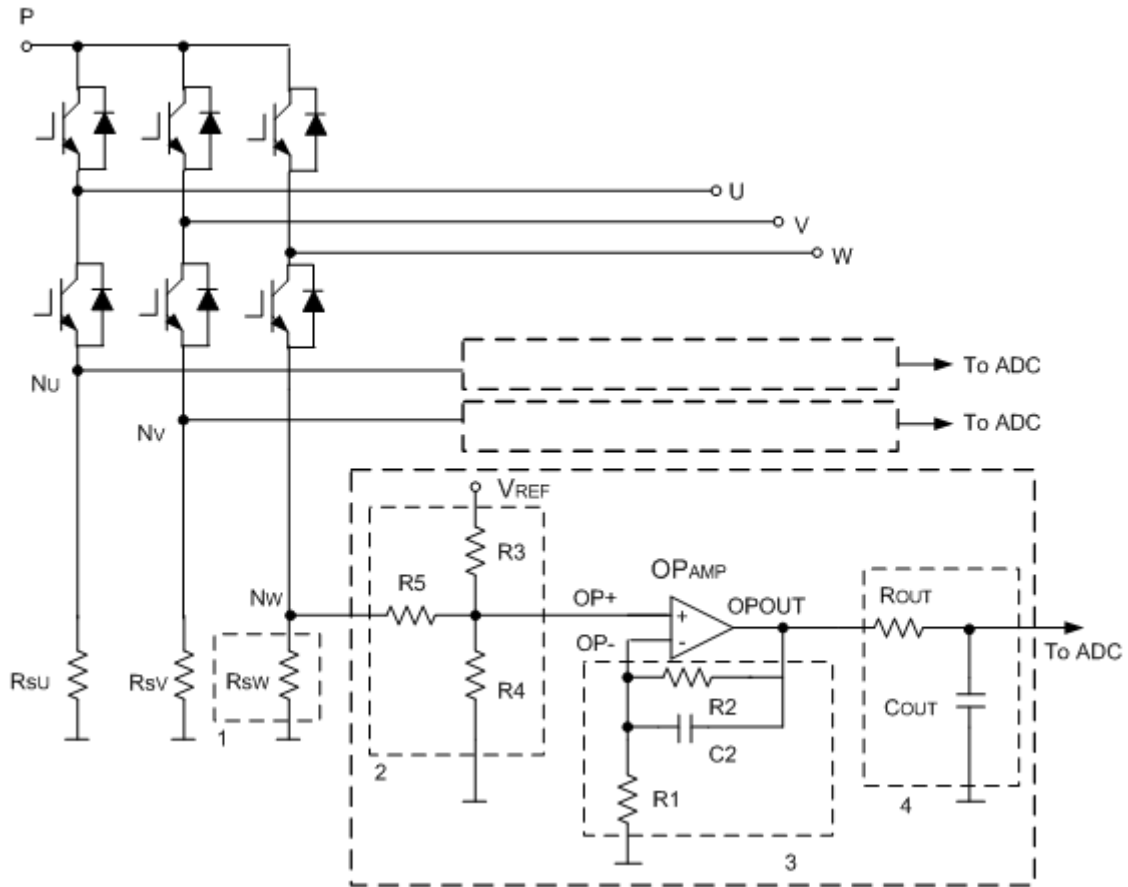


Figure 14. Current Sense Scheme

Description:

- 1、 Half-bridge current sensing
- 2、 Voltage shifting of the V_{sense}
- 3、 Voltage gain and filtering
- 4、 Capacitor required by the ADC for sampling purpose

R_{OUT} resistor is usually required in order to make the OP_{AMP} stable when the C_{OUT} capacitance increases

Design Reference:

1. R_1 : 1.0 K Ω
2. R_2 : 5.6 K Ω
3. R_3 : 4.7 K Ω
4. R_4 : 910 Ω
5. R_5 : 910 Ω
6. R_{OUT} : 1.0 K Ω
7. C_2 :10pF (Ceramic)

Precautions on Electrostatic Electricity

- (1) Operators must wear anti-static clothing and conductive shoes (or a leg or heel strap).
- (2) Operators must wear a wrist strap grounded to earth via a resistor of about 1 M Ω .
- (3) Soldering irons must be grounded from iron tip to earth, and must be used only at low voltages.
- (4) If the tweezers you use are likely to touch the device terminals, use anti-static tweezers and in particular avoid metallic tweezers. If a charged device touches a low-resistance tool, rapid discharge can occur. When using vacuum tweezers, attach a conductive chucking pat to the tip, and connect it to a dedicated ground used especially for anti-static purposes (suggested resistance value: 10⁴ to 10⁸ Ω).
- (5) Do not place devices or their containers near sources of strong electrical fields (such as above a CRT).
- (6) When storing printed circuit boards which have devices mounted on them, use a board container or bag that's protected against static charge. To avoid the occurrence of static charge or discharge due to friction, keep the boards separate from one other and do not stack them directly on top of one another.
- (7) Ensure, if possible, that any articles (such as clipboards) which are brought to any location where the level of static electricity must be closely controlled are constructed of anti-static materials.
- (8) In cases where the human body comes into direct contact with a device, be sure to wear anti-static finger covers or gloves (suggested resistance value: 10⁸ Ω or less).
- (9) Equipment safety covers installed near devices should have resistance ratings of 10⁹ Ω or less.
- (10) If a wrist strap cannot be used for some reason, and there is a possibility of imparting friction to devices, use an ionizer.

CONFIDENTIALITY OBLIGATIONS:

This document contains sensitive information and classified “**CONFIDENTIAL**”.

Please make sure you should comply with the following security rules at all times

Do not copy or reproduce all or part of this document and further copies can be provided on a “need to know basis”, please contact your local Starpower sales office.

PLEASE READ CAREFULLY:

Starpower reserve the right to make changes, corrections, modifications or improvements, to this document, and the products and services described herein at anytime, without notice. Starpower assumes no liability whatsoever relating to the choice, selection or use of the Starpower products and services described herein.

And purchasers are solely responsible for the choice, selection and use of the Starpower products and services described herein, No license, express or implied, to any intellectual property rights is granted under this document. If any part of this document refers to any third party products or services it shall not be deemed a license grant by Starpower for the use of such third party products or services, or any intellectual property contained therein or considered as a warranty covering the use in any manner whatsoever of such third party products or services or any intellectual property contained therein. Unless otherwise set forth in Starpower terms and conditions of sale Starpower disclaims any express or implied warranty with respect to the use and/or sale of Starpower products including without limitation implied warranties of merchantability, fitness for a particular purpose (and their equivalents under the laws of any jurisdiction), or infringement of any patent, copyright or other intellectual property right. Unless expressly approved in writing by an authorized Starpower representative, Starpower products are not recommended, authorized or warranted for use in military, air craft, space, life saving, or life sustaining applications, nor in products or systems where failure or malfunction may result in personal injury, death, or severe property or environmental damage.

Information in this document supersedes and replaces all information previously supplied.

www.powersemi.cc