

STARPOWER

SEMICONDUCTOR

SiC MOSFET

MD29HTS120P6HET

1200V/2.90mΩ 6 in one-package

General Description

STARPOWER SiC MOSFET Power Module provides very low $R_{DS(on)}$ as well as high blocking voltage.

It's designed for the applications such as hybrid and electric vehicle.

Features

- SiC power MOSFET
- High blocking voltage with low $R_{DS(on)}$
- Easy to parallel and simple to drive
- Low inductance case avoid oscillations
- Isolated copper pinfin baseplate using Si_3N_4 AMB technology

Typical Applications

- Automotive application
- Hybrid and electric vehicle
- Inverter for motor drive

Equivalent Circuit Schematic

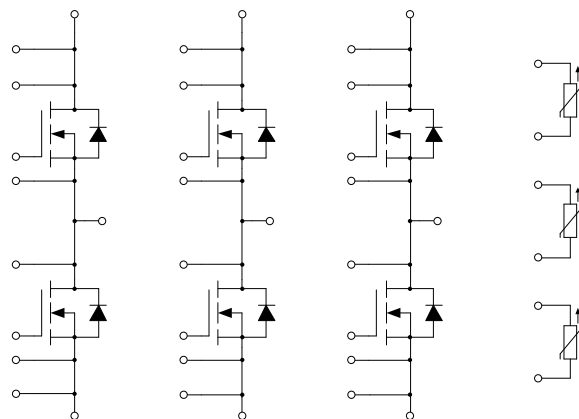

Absolute Maximum Ratings $T_F=25^{\circ}\text{C}$ unless otherwise noted**MOSFET**

Symbol	Description	Value	Unit
V_{DSS}	Drain-Source Voltage	1200	V
V_{GSSmax}	Gate-Source Voltage	-8/+19	V
V_{GSSop}	Gate-Source Voltage	-4/+15	V
I_D	Drain Current @ $T_F=60^{\circ}\text{C}$	390	A
I_{DRM}	Repetitive Peak Drain Current tp limited by T_{vjop}	780	A
P_D	Maximum Power Dissipation @ $T_F=60^{\circ}\text{C}$ $T_{vj}=175^{\circ}\text{C}$	891	W

Body Diode

Symbol	Description	Value	Unit
I_S	Source Current @ $T_F=60^{\circ}\text{C}$	216	A

Module

Symbol	Description	Value	Unit
T_{vjmax}	Maximum Junction Temperature	175	$^{\circ}\text{C}$
T_{vjop}	Operating Junction Temperature	-40 to +175	$^{\circ}\text{C}$
T_{STG}	Storage Temperature Range	-40 to +125	$^{\circ}\text{C}$
V_{ISO}	Isolation Voltage RMS, $f=50\text{Hz}$, $t=1\text{min}$	3000	V

MOSFET Characteristics $T_F=25^\circ\text{C}$ unless otherwise noted

Symbol	Parameter	Test Conditions	Min.	Typ.	Max.	Unit	
$R_{DS(on)}$	Static Drain-Source On-Resistance	$I_D=450\text{A}, V_{GS}=15\text{V}, T_{vj}=25^\circ\text{C}$		2.90		m Ω	
		$I_D=450\text{A}, V_{GS}=15\text{V}, T_{vj}=150^\circ\text{C}$		4.53			
		$I_D=450\text{A}, V_{GS}=15\text{V}, T_{vj}=175^\circ\text{C}$		4.77			
$V_{GS(th)}$	Gate-Source Threshold Voltage	$I_D=125\text{mA}, V_{DS}=V_{GS}, T_{vj}=25^\circ\text{C}$		2.6		V	
I_{DSS}	Drain-Source Leakage Current	$V_{DS}=V_{DSS}, V_{GS}=0\text{V}, T_{vj}=25^\circ\text{C}$			500	μA	
I_{GSS}	Gate-Source Leakage Current	$V_{GS}=19\text{V}, V_{DS}=0\text{V}, T_{vj}=25^\circ\text{C}$			600	nA	
R_{Gint}	Internal Gate Resistance			1.75		Ω	
C_{iss}	Input Capacitance	$V_{GS}=0\text{V}, V_{DS}=800\text{V}, f=100\text{kHz}$		39.3		nF	
C_{oss}	Output Capacitance			1.28		nF	
C_{rss}	Reverse Transfer Capacitance			0.05		nF	
Q_g	Total Gate Charge	$I_D=450\text{A}, V_{DS}=800\text{V}, V_{GS}=-4/+15\text{V}$		1.13		μC	
$t_{d(on)}$	Turn-On Delay Time	$V_{DS}=800\text{V}, I_D=450\text{A}, R_{Gon}=6.8\Omega, R_{Goff}=3.9\Omega, L_S=25\text{nH}, V_{GS}=-4/+15\text{V}, T_{vj}=25^\circ\text{C}$		196		ns	
t_r	Rise Time			97		ns	
$t_{d(off)}$	Turn-Off Delay Time			233		ns	
t_f	Fall Time			46		ns	
E_{on}	Turn-On Switching Loss				30.6		mJ
E_{off}	Turn-Off Switching Loss				15.2		mJ
$t_{d(on)}$	Turn-On Delay Time		$V_{DS}=800\text{V}, I_D=450\text{A}, R_{Gon}=6.8\Omega, R_{Goff}=3.9\Omega, L_S=25\text{nH}, V_{GS}=-4/+15\text{V}, T_{vj}=150^\circ\text{C}$		197		ns
t_r	Rise Time				99		ns
$t_{d(off)}$	Turn-Off Delay Time			334		ns	
t_f	Fall Time			54		ns	
E_{on}	Turn-On Switching Loss				32.1		mJ
E_{off}	Turn-Off Switching Loss				18.4		mJ
$t_{d(on)}$	Turn-On Delay Time	$V_{DS}=800\text{V}, I_D=450\text{A}, R_{Gon}=6.8\Omega, R_{Goff}=3.9\Omega, L_S=25\text{nH}, V_{GS}=-4/+15\text{V}, T_{vj}=175^\circ\text{C}$			198		ns
t_r	Rise Time				100		ns
$t_{d(off)}$	Turn-Off Delay Time			342		ns	
t_f	Fall Time			58		ns	
E_{on}	Turn-On Switching Loss				32.4		mJ
E_{off}	Turn-Off Switching Loss				18.5		mJ

Body Diode Characteristics $T_F=25^\circ\text{C}$ unless otherwise noted

Symbol	Parameter	Test Conditions	Min.	Typ.	Max.	Unit
V_{SD}	Diode Forward Voltage	$I_{SD}=228\text{A}, V_{GS}=-4\text{V}, T_{vj}=25^\circ\text{C}$		4.35		V
		$I_{SD}=228\text{A}, V_{GS}=-4\text{V}, T_{vj}=175^\circ\text{C}$		3.80		

NTC Characteristics $T_F=25^\circ\text{C}$ unless otherwise noted

Symbol	Parameter	Test Conditions	Min.	Typ.	Max.	Unit
R_{25}	Rated Resistance			5.0		$\text{k}\Omega$
$\Delta R/R$	Deviation of R_{100}	$T_1=100^\circ\text{C}, R_{100}=493.3\Omega$	-5		5	%
P_{25}	Power Dissipation				20.0	mW
$B_{25/50}$	B-value	$R_2=R_{25}\exp[B_{25/50}(1/T_2-1/(298.15\text{K}))]$		3375		K
$B_{25/80}$	B-value	$R_2=R_{25}\exp[B_{25/80}(1/T_2-1/(298.15\text{K}))]$		3411		K
$B_{25/100}$	B-value	$R_2=R_{25}\exp[B_{25/100}(1/T_2-1/(298.15\text{K}))]$		3433		K

Module Characteristics $T_F=25^\circ\text{C}$ unless otherwise noted

Symbol	Parameter	Min.	Typ.	Max.	Unit
L_{CE}	Stray Inductance		8		nH
$R_{CC'+EE'}$	Module Lead Resistance, Terminal to Chip		0.43		$\text{m}\Omega$
p	Maximum Pressure In Cooling Circuit			2.5	bar
R_{thJF}	Junction-to-Cooling Fluid (per MOSFET) $\Delta V/\Delta t=10.0\text{dm}^3/\text{min}, T_F=60^\circ\text{C}$		0.117	0.129	K/W
M	Terminal Connection Torque, Screw M5	3.6		4.4	N.m
	Mounting Torque, Screw M4	1.8		2.2	
G	Weight of Module		792		g

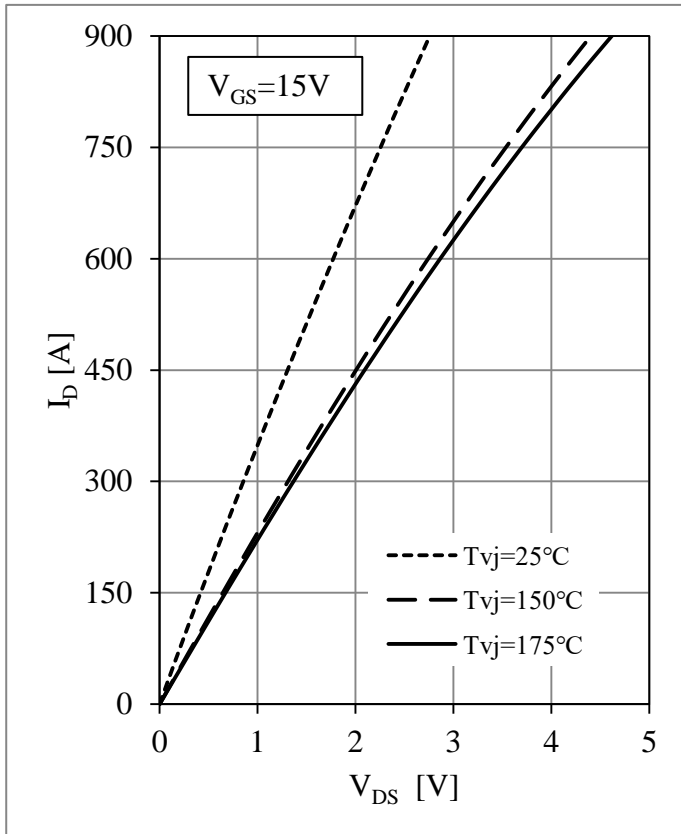

Fig 1. MOSFET Output Characteristics

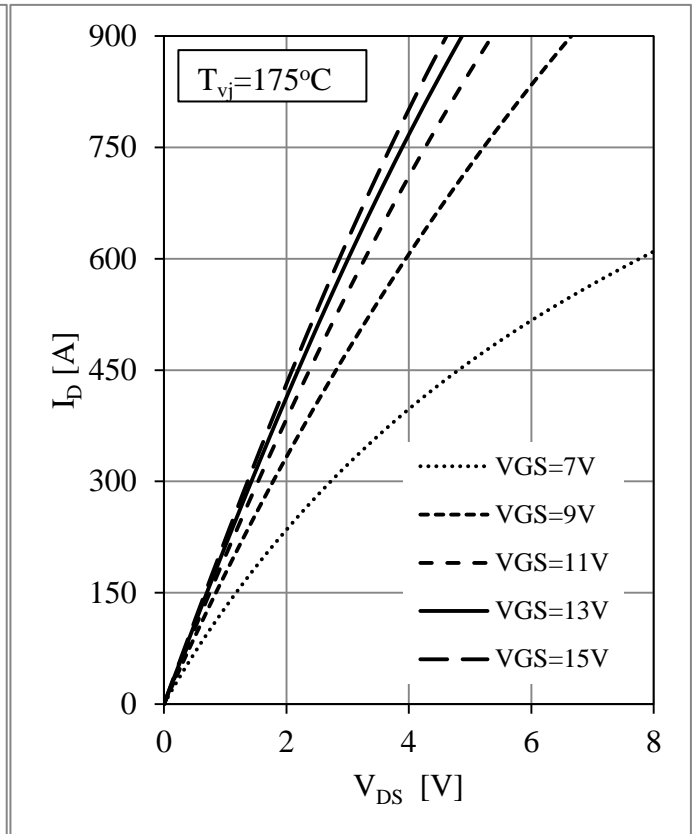

Fig 2. MOSFET Output Characteristics

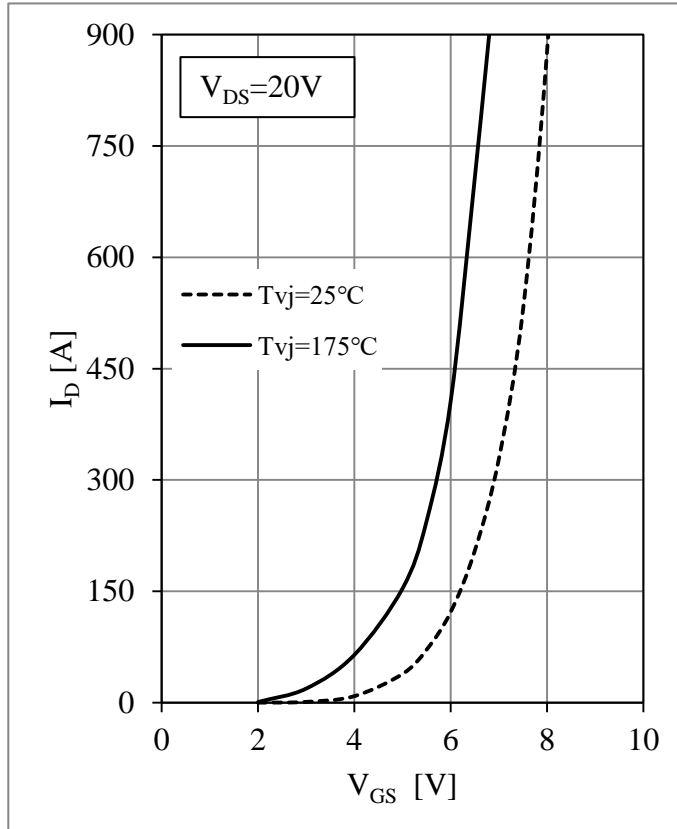

Fig 3. MOSFET Transfer Characteristics

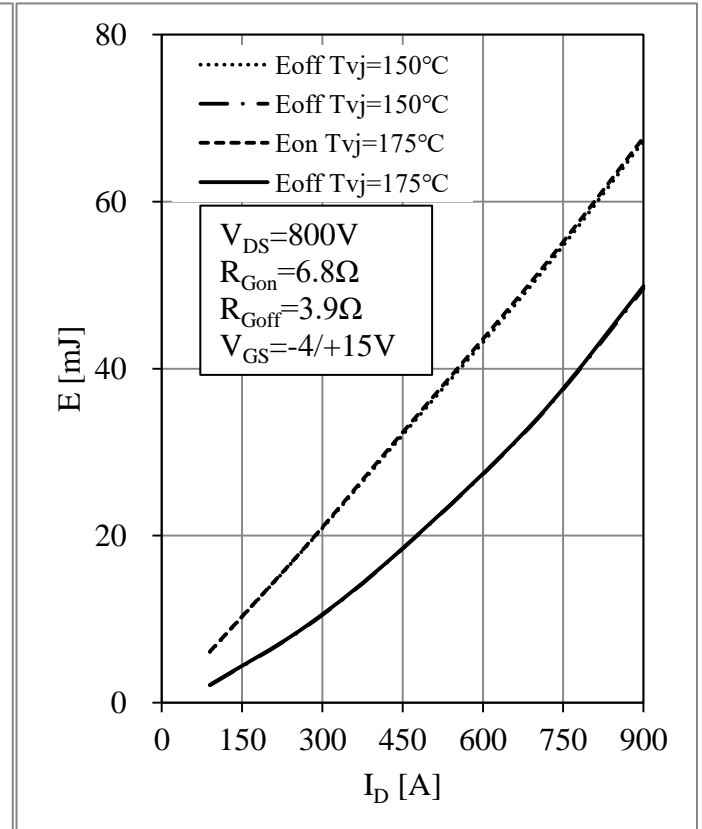

Fig 4. MOSFET Switching Loss vs. I_{DS}

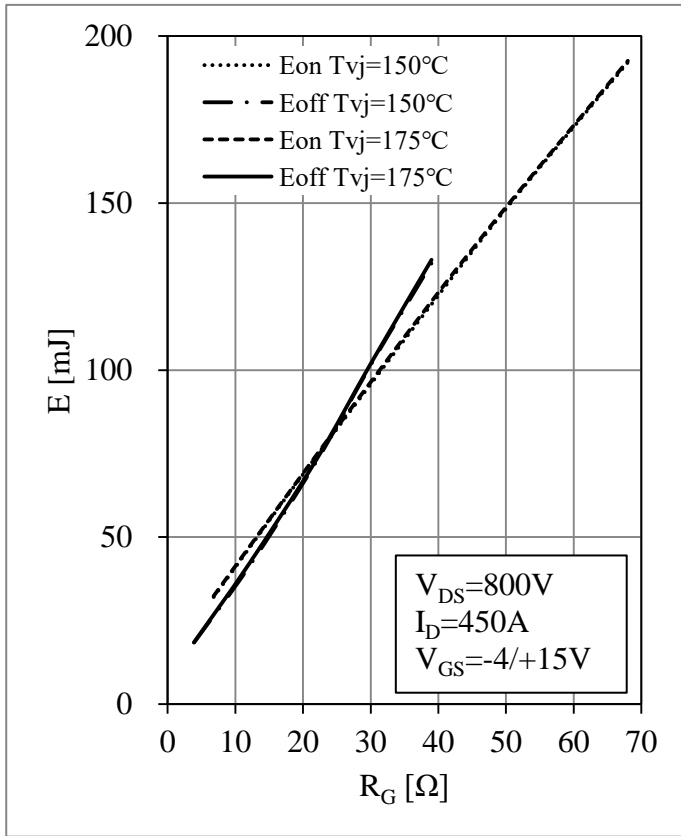

Fig 5. MOSFET Switching Loss vs. R_G

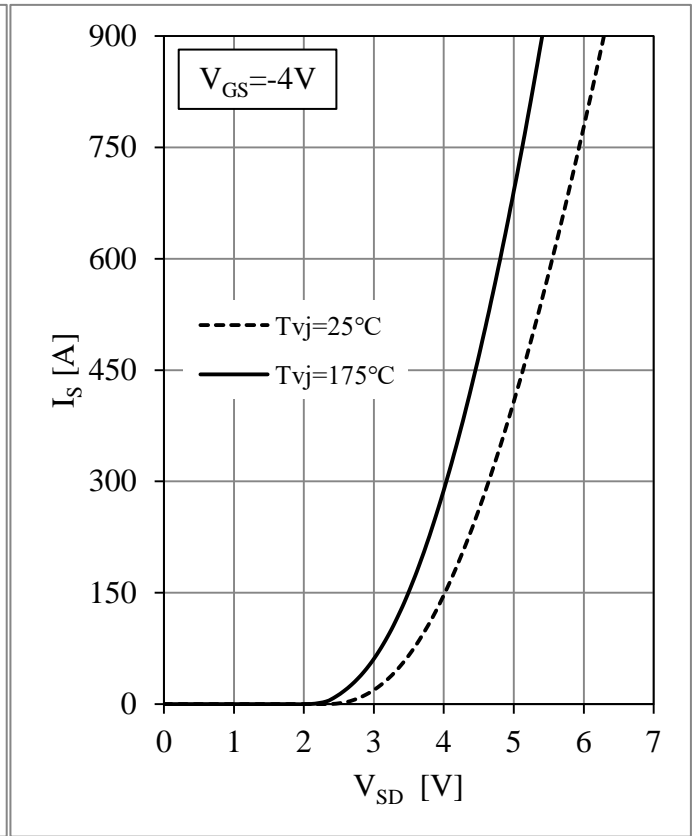

Fig 6. Body Diode Characteristics

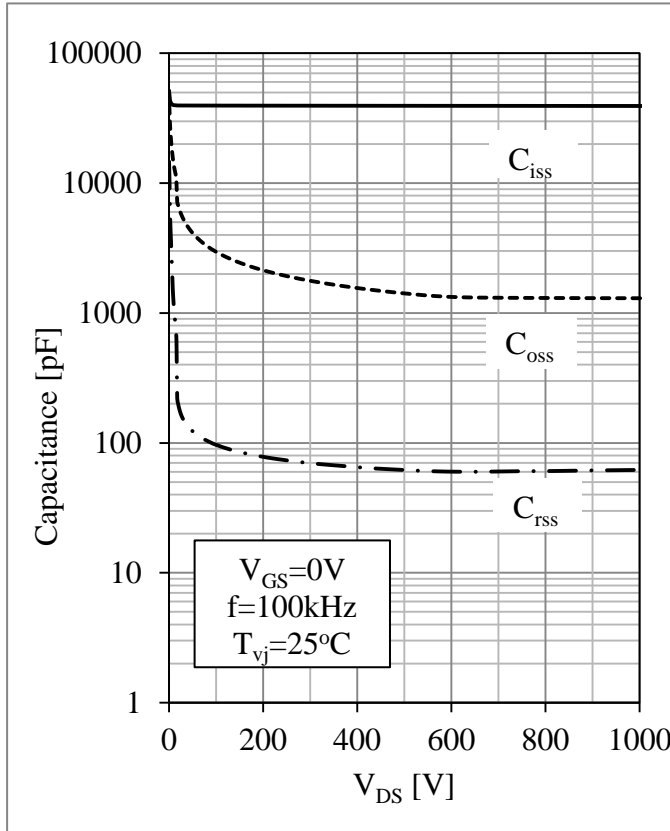

Fig 7. Capacitance vs. V_{DS}

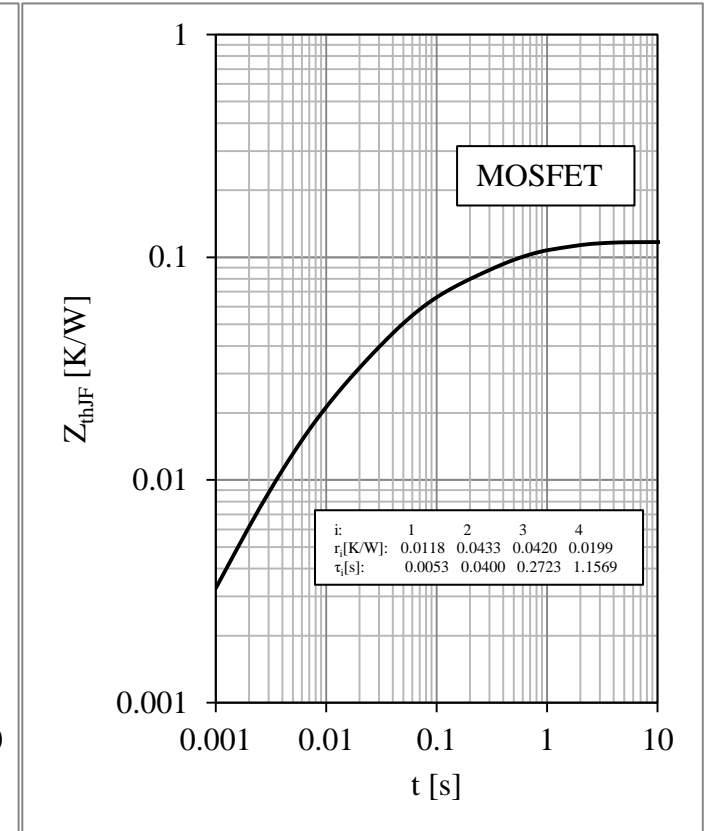

Fig 8. MOSFET Transient Thermal Impedance

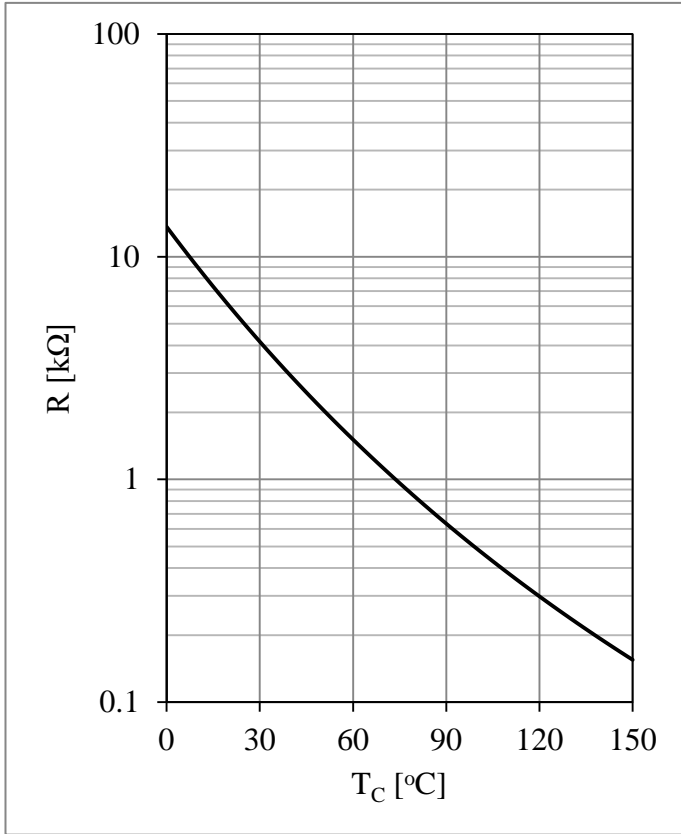
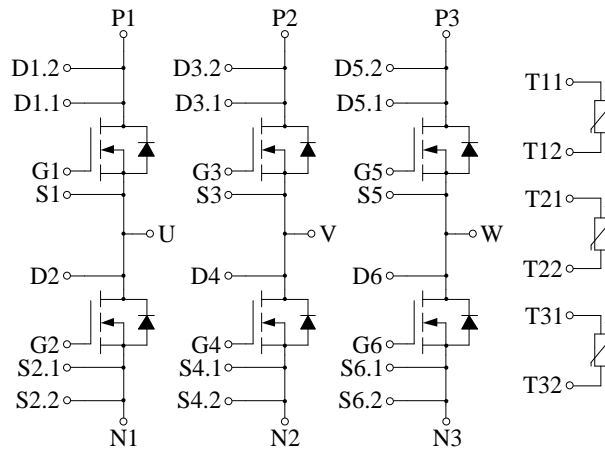

Fig 9. NTC Temperature Characteristic

Circuit Schematic



Package Dimensions

Dimensions in Millimeters

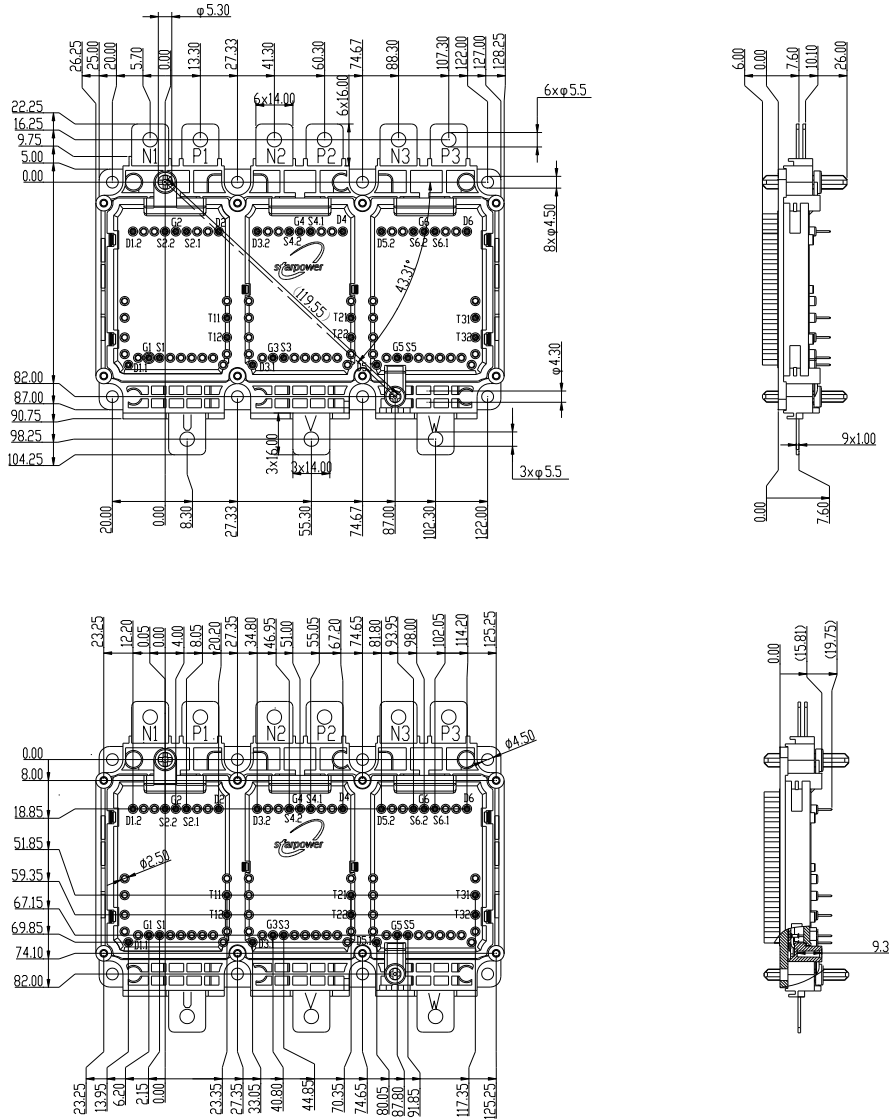

Terms and Conditions of Usage

The data contained in this product datasheet is exclusively intended for technically trained staff. you and your technical departments will have to evaluate the suitability of the product for the intended application and the completeness of the product data with respect to such application.

This product data sheet is describing the characteristics of this product for which a warranty is granted. Any such warranty is granted exclusively pursuant the terms and conditions of the supply agreement. There will be no guarantee of any kind for the product and its characteristics.

Should you require product information in excess of the data given in this product data sheet or which concerns the specific application of our product, please contact the sales office, which is responsible for you (see www.powersemi.cc), For those that are specifically interested we may provide application notes.

Due to technical requirements our product may contain dangerous substances. For information on the types in question please contact the sales office, which is responsible for you.

Should you intend to use the Product in aviation applications, in health or live endangering or life support applications, please notify.

If and to the extent necessary, please forward equivalent notices to your customers.
Changes of this product data sheet are reserved.